

GT4E.1

new generation rc car

1/8 SCALE 4WD GT ELECTRIC



INSTRUCTION MANUAL



PROFESSIONAL RC CAR

www.wrc-racing.com



INTRODUCTION

GT4E is a new generation high quality 1/8 scale GT electric car.
GT4E is supplied in a box, you can download the Instruction manual from www.wrc-racing.com
Its use is intended for more than 16 years old persons with experience on rc model car field.
Children and all the persons without this requirement MUST have direct supervision of a knowledgeable adult responsible.

SAFETY PRECAUTIONS

Instruction Manual MUST be read and fully understood before to start building and operating functions.
Always keep Instruction Manual in safety place, ready to be consulted for any reference you need.
Use only original WRC spare parts.

GENERAL INFORMATION

Assemble the kit only away from the reach of children.
Follow the building and operating instructions using the utmost care.
Don't put any part of your body inside rotating and moving elements as this may cause damage or serious injury.
Check and clean the model before putting it away.
Don't use your model car in public places or in roads and areas where it could generate conflict with person or vehicular traffic.
The model car is controlled by radio: you MUST put great care to avoid loss of radio control always keeping a safety margin all around your model in order to prevent any collision.
Operating frequency: check and be sure it is clear and not shared with anybody at same time; it could cause loss of control of the RC model.
Always turn on your transmitter before you turn on the receiver in the car and always turn off the receiver before you turn off your transmitter.
Keep the wheels of the model off the ground when checking the operation of the radio equipment.
Disconnect the battery pack before storing your model.

WARRANTY

WRC guarantees this model kit to be free from defects in both material and workmanship within 30 days of purchase.
The total monetary value under warranty will in no case exceed the cost of the original kit purchased.
This warranty doesn't cover any components damaged by use or modification or as result of wear.
Part or parts missing from this kit must be reported within 30 days of purchase.
No part or parts will be sent under warranty without proof of purchase.
If you find a defective or missing part, contact the local distributor.
Customer service and support will be provided through local hobby store.
No warranties are expressed or implied that cover damage caused by what is considered normal use or cover or imply how long any model cars' components or electric components will last before requiring replacement.
Due to the high performance level of this model car you will need to periodically maintain and replace consumable components; any and all warranty coverage will not cover replacement of any part or component damaged by neglect, abuse or improper or unreasonable use.
This includes but is not limited to damage from crashing, excessive moisture, improper use or no maintenance or user modifications which compromise the integrity of components.
Warranty will not cover components that are considered consumable on RC model car.
WRC doesn't pay nor refund on any component sent from WRC or its distributor for warranty.
WRC reserves the right to make final determination of the warranty status of any component or part
Use only original WRC spare part:

CUSTOMER SUPPORT

Please don't hesitate to contact WRC support at info@wrc-racing.com for any problem or question.
Also kindly visit our website www.wrc-racing.com to find last updates, set-up information, option parts and other information.

W.R.C. world racing car s.r.l.

Via A. Volta 2 Bis
36040 Brendola (VI)
ITALY

Phone: 0039 0 444 1792263
E-mail: info@wrc-racing.com
Website: www.wrc-racing.com



GT4E

TECHNICAL INFORMATION

- BRAKE:Laser cut brake disc with Ferodo brake pad
- WHEELS LOCK:Lightweight 17 mm 7075 T6 Nut
- CHASSIS:4.0 mm Swiss 7075 T6 aluminium
- RADIO PLATE:Composite Material
- DRIVETRAIN TYPE:Spring steel CVD Driveshfts
- FRONT DIFFERENTIAL:Differential Gear
- REAR DIFFERENTIAL:Differential Gear
- SUSPENSION:Pivot ball suspension
- RIDE HEIGHT:Adjustable Front & Rear
- CAMBER:Adjustable Front & Rear
- CASTER:Adjustable Front
- TOE:Adjustable Front & Rear
- ROLLCENTER:Adjustable Front & Rear
- ACKERMANN:Adjustable Front
- ANTI-ROLL BARS:Adjustable Front & Rear

TECHNICAL DATA

- WIDTH310 mm
- WHEEL BASEadjustable 315-320 mm
- WEIGHT READY TO RUN3500g

ADDITIONAL ITEMS NEEDED FOR COMPLETION (REQUIRED BUT NOT INCLUDED IN THE KIT)



ELECTRIC MOTOR



TRANSMITTER



RECEIVER

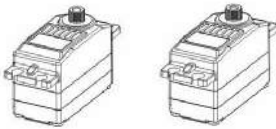

2 LOW PROFILE STEERING SERVO

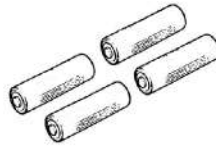

AA ALKALINE BATTERIES
FOR TRANSMITTER
AND RECEIVER



WHEEL - TYRES - INSERTS

2 X 7.4 V

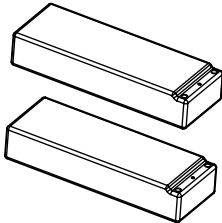

LIPO BATTERIES

TOOLS REQUIRED

THESE TOOLS ARE NOT INCLUDED IN THE KIT BUT ARE REQUIRED FOR PROPER ASSEMBLY

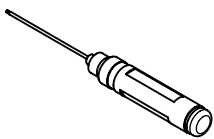

ALLEN:
1.5 MM.
2.0 MM.
2.5 MM.
3.0 MM.

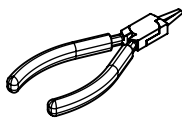

RING PLIERS

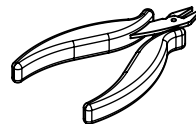

SIDE CUTTER

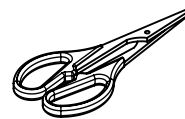

SCISSORS

NOTICE:

THE FOLLOWING ITEMS ARE NEEDED FOR COMPLETION OF THE GT4E; THEY ARE NOT INCLUDED IN THIS KIT (UNLESS NOTED) AND SHOULD BE OBTAINED FROM YOUR LOCAL HOBBY SHOP.
BE SURE TO READ THE INSTRUCTION COMPLETELY PRIOR TO ASSEMBLY

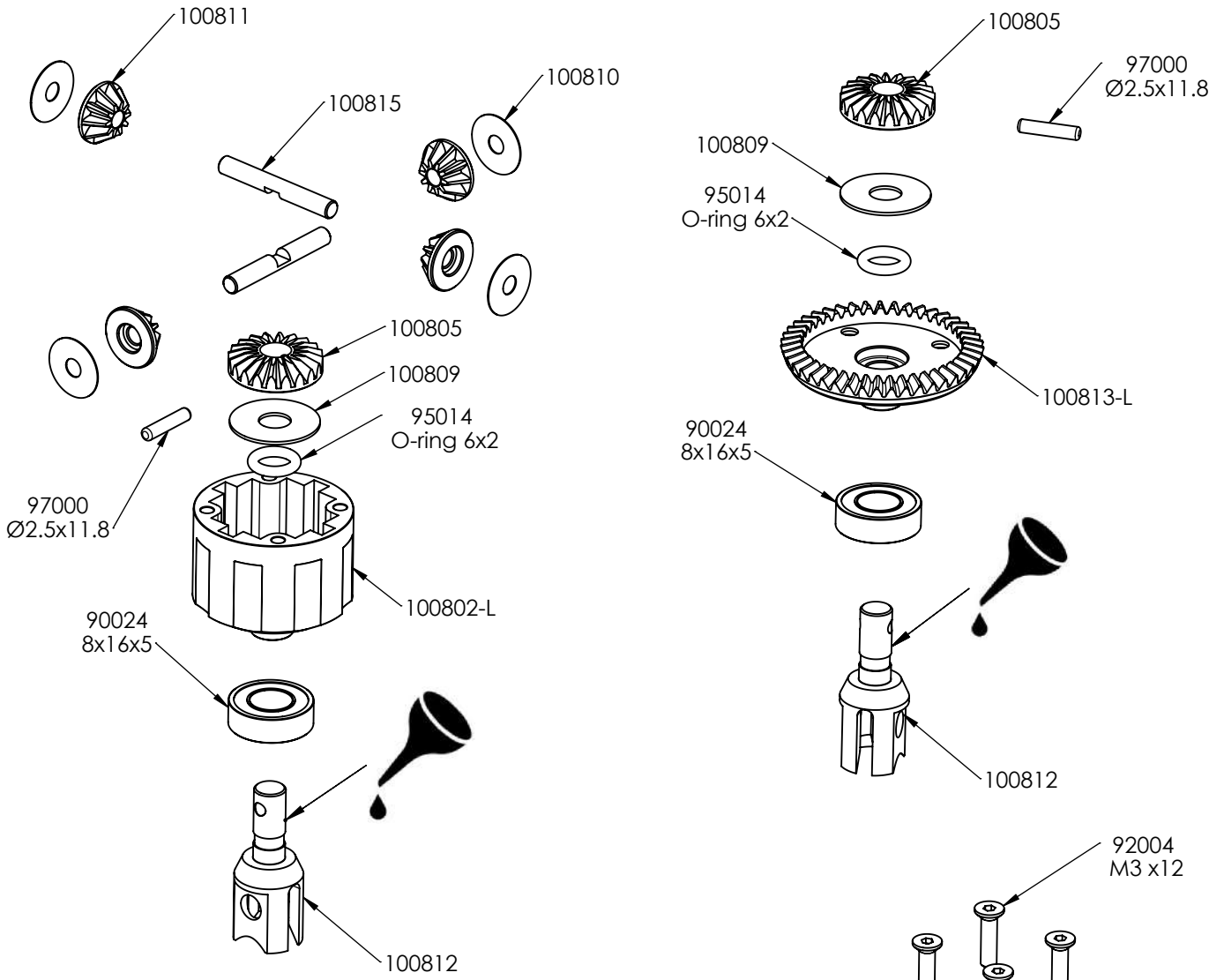

DIFFERENTIAL OIL :
 Front : 500000 cst
 Weight : 3 g

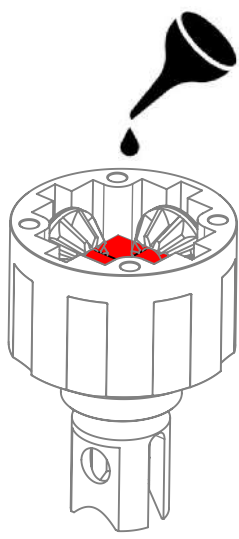

Fill the differential up to the top of the pin.
 DO NOT fill the diff. to the top of the housing.

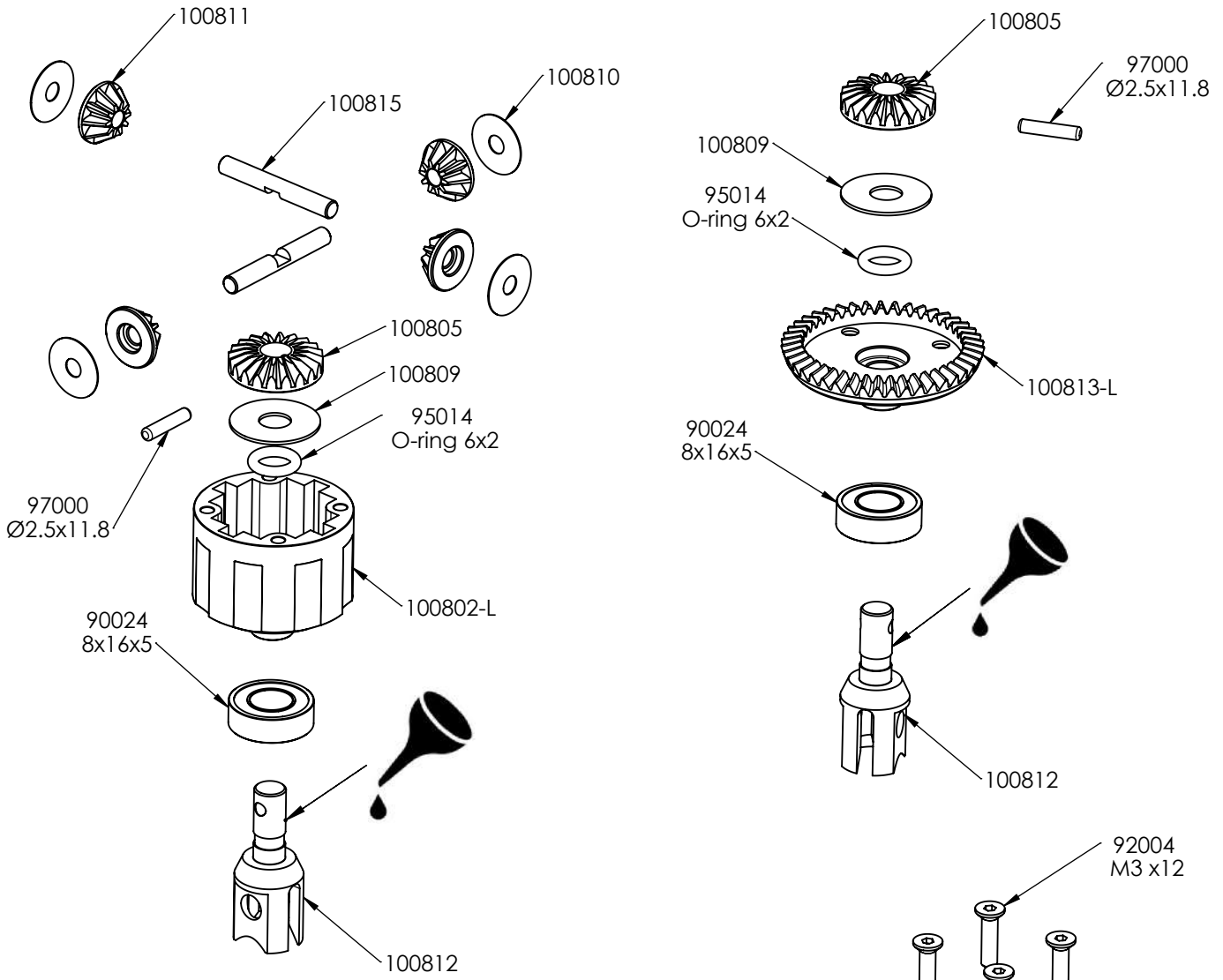

DIFFERENTIAL OIL :
Rear : 40000 cst
Weight : 3 g

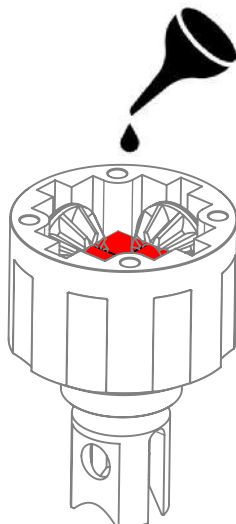

**Fill the differential up to the top of the pin.
 DO NOT fill the diff. to the top of the housing.**

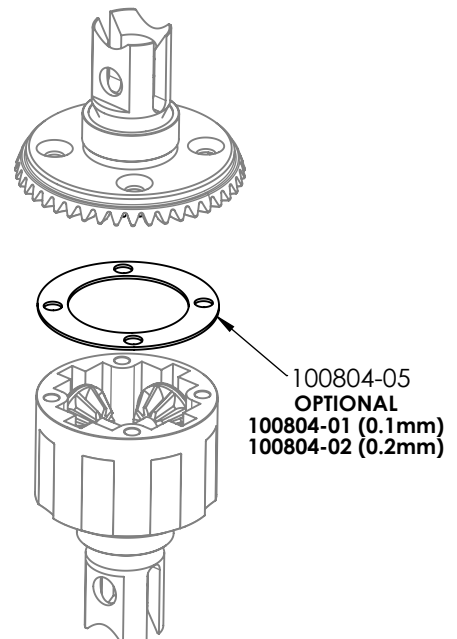

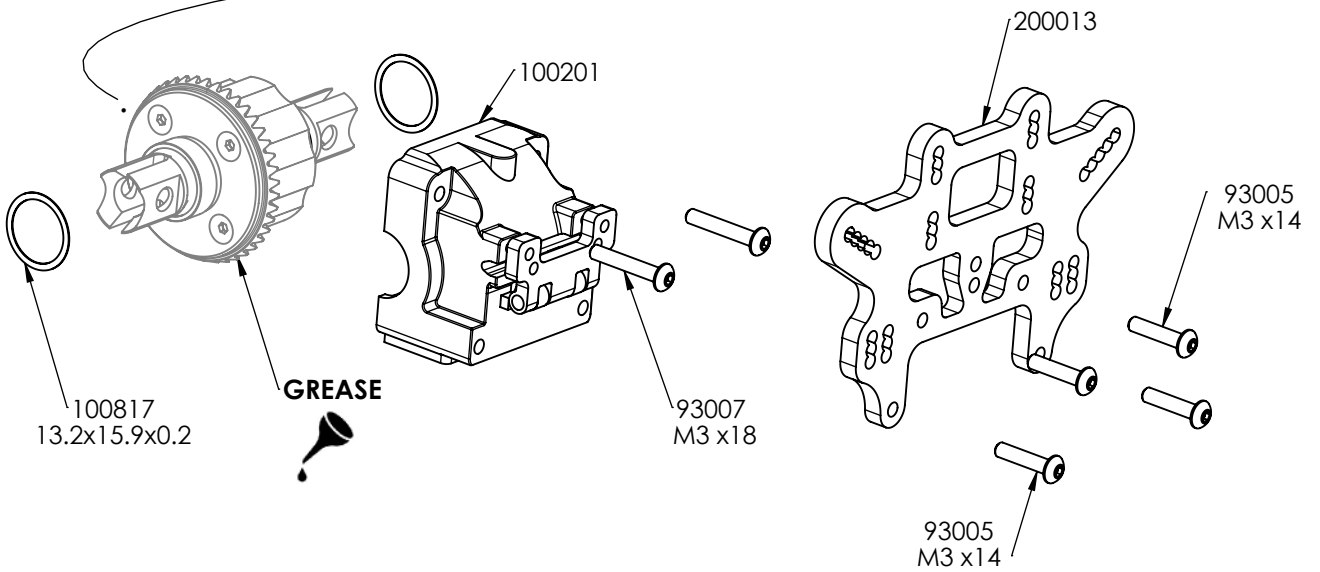
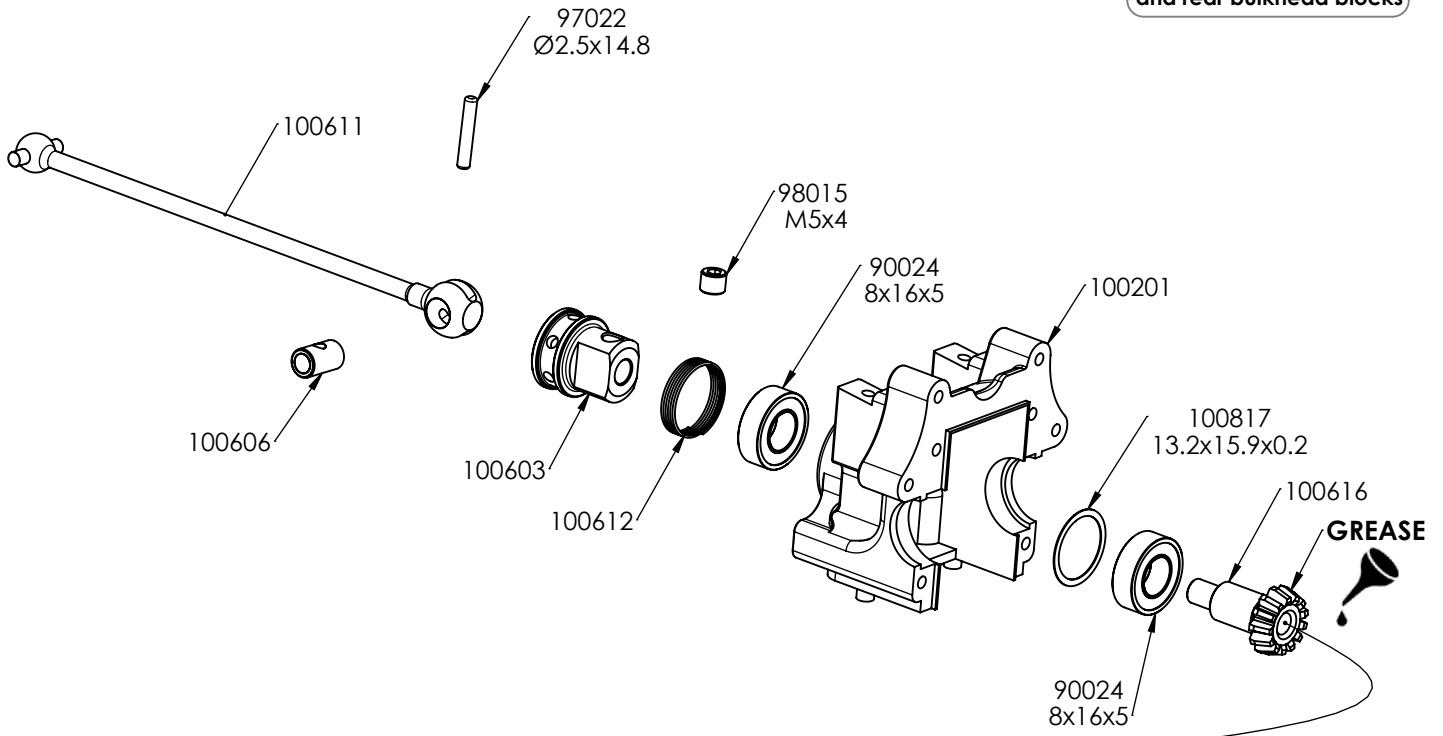
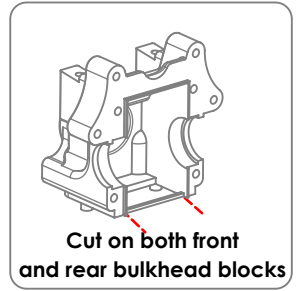

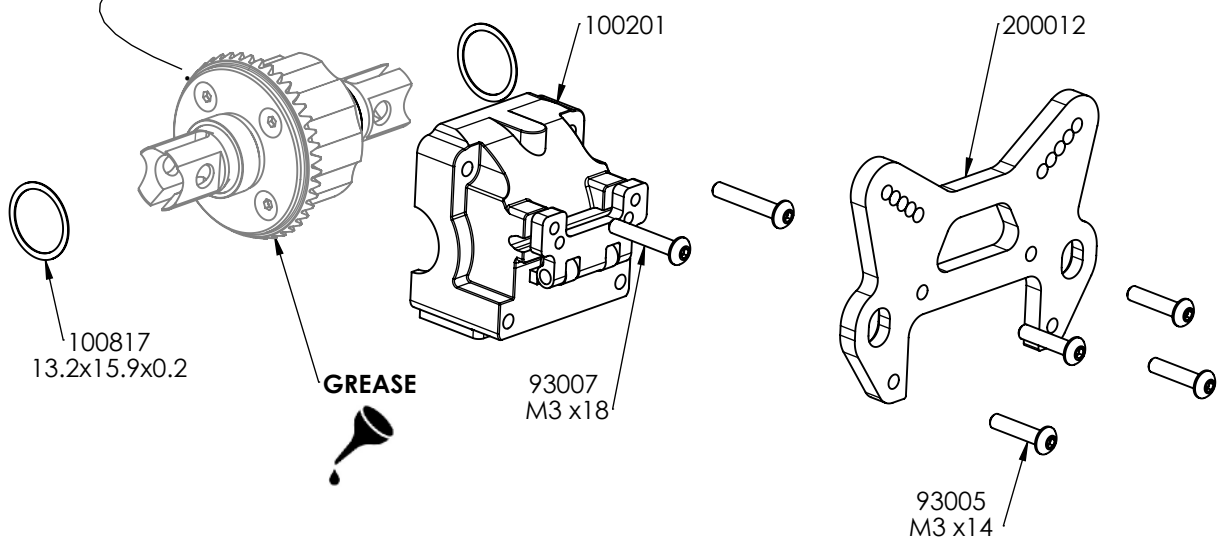
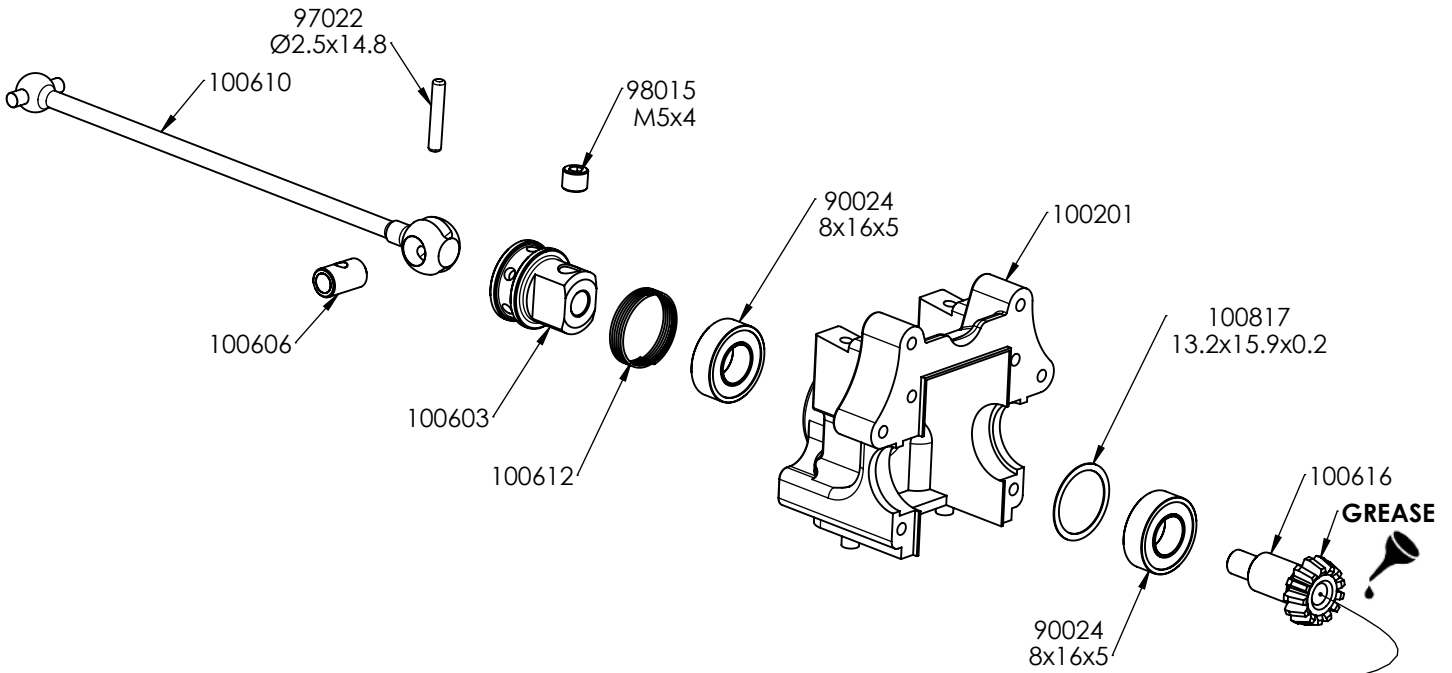
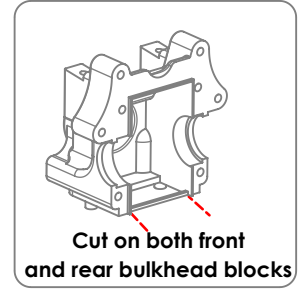

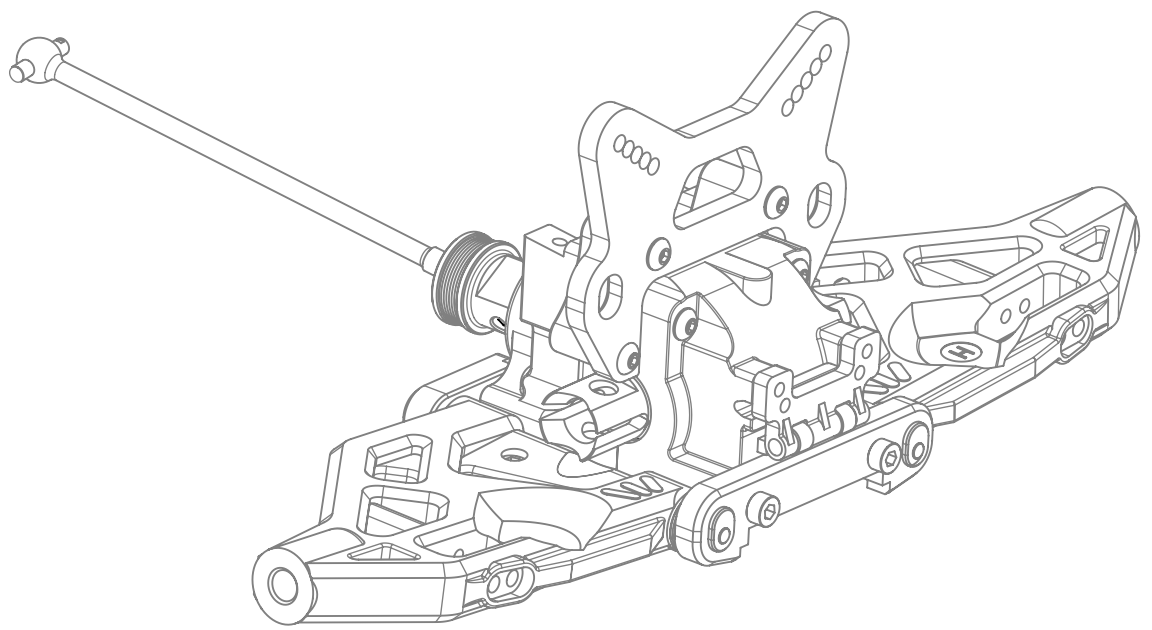
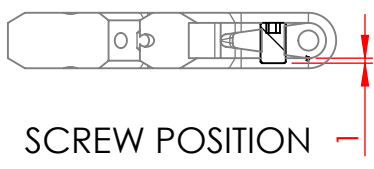
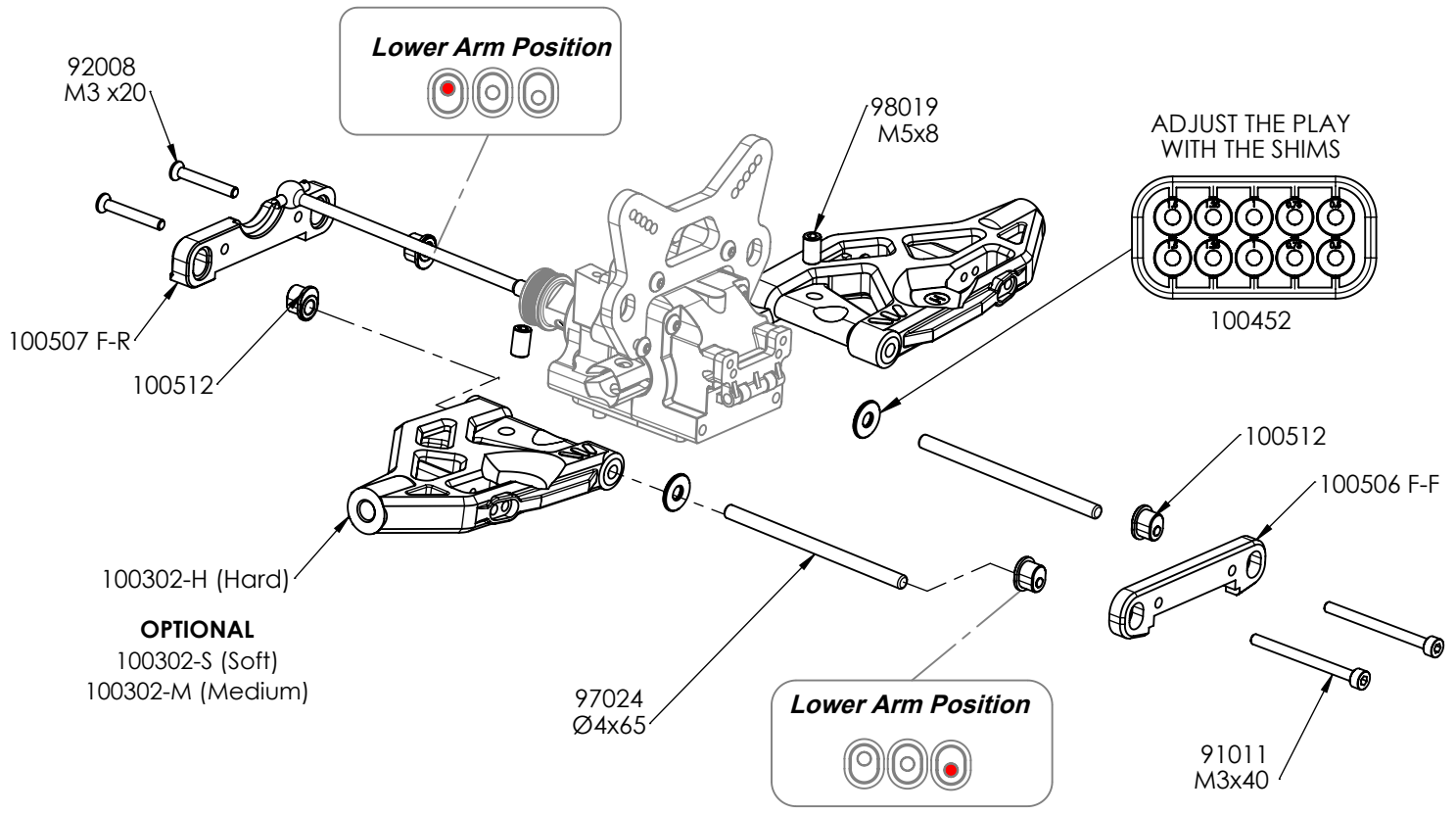

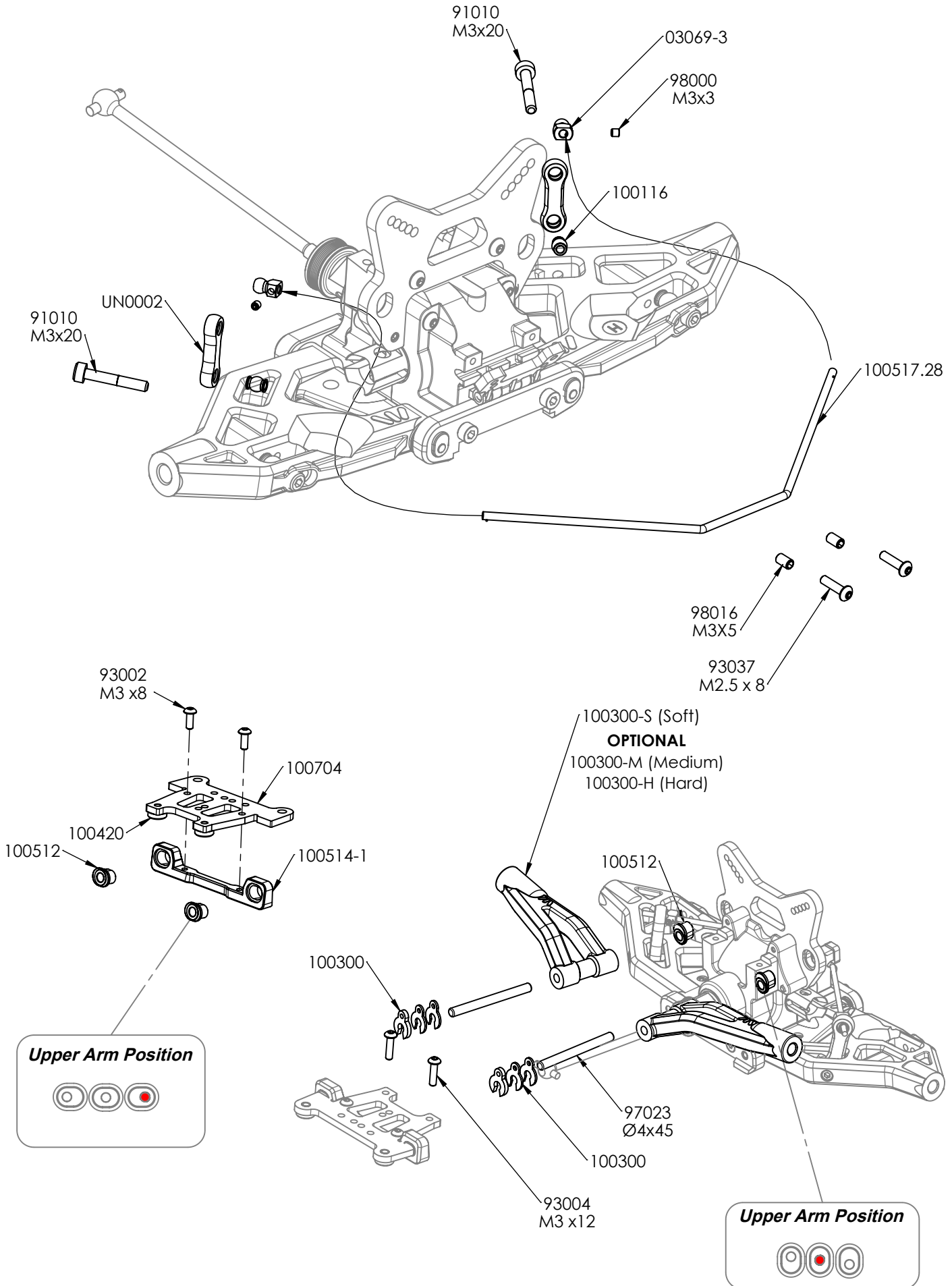

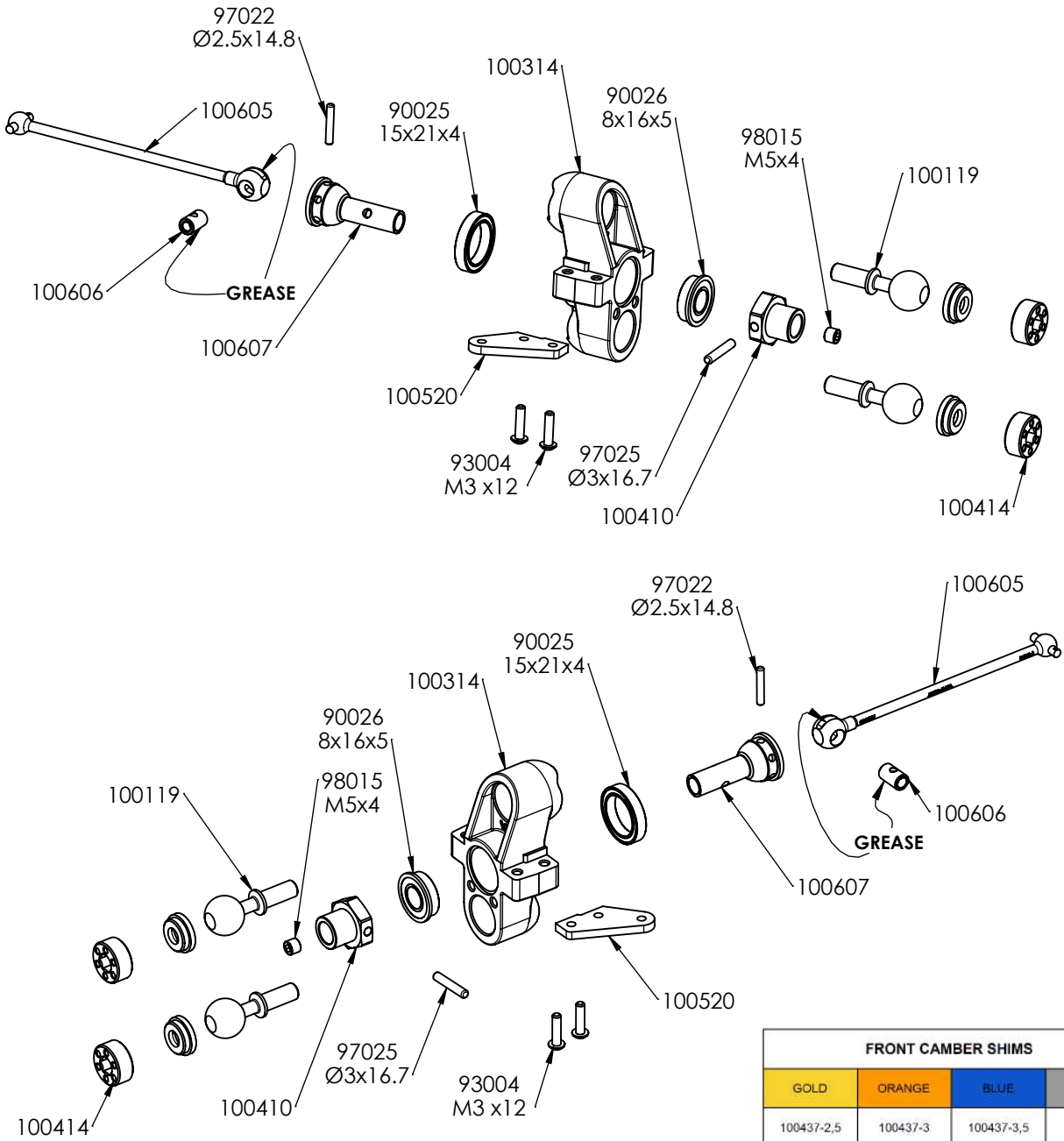

FRONT CAMBER SHIMS			
GOLD	ORANGE	BLUE	GREY
100437-2.5	100437-3	100437-3.5	100437-4
CAMBER VALUE 2°	CAMBER VALUE 1.5°	CAMBER VALUE 1°	CAMBER VALUE 0.5°

100437-3.5 (3.5mm)
OPTIONAL
 100437-2.5 (2.5mm)
 100437-3 (3mm)
 100437-4 (4mm)

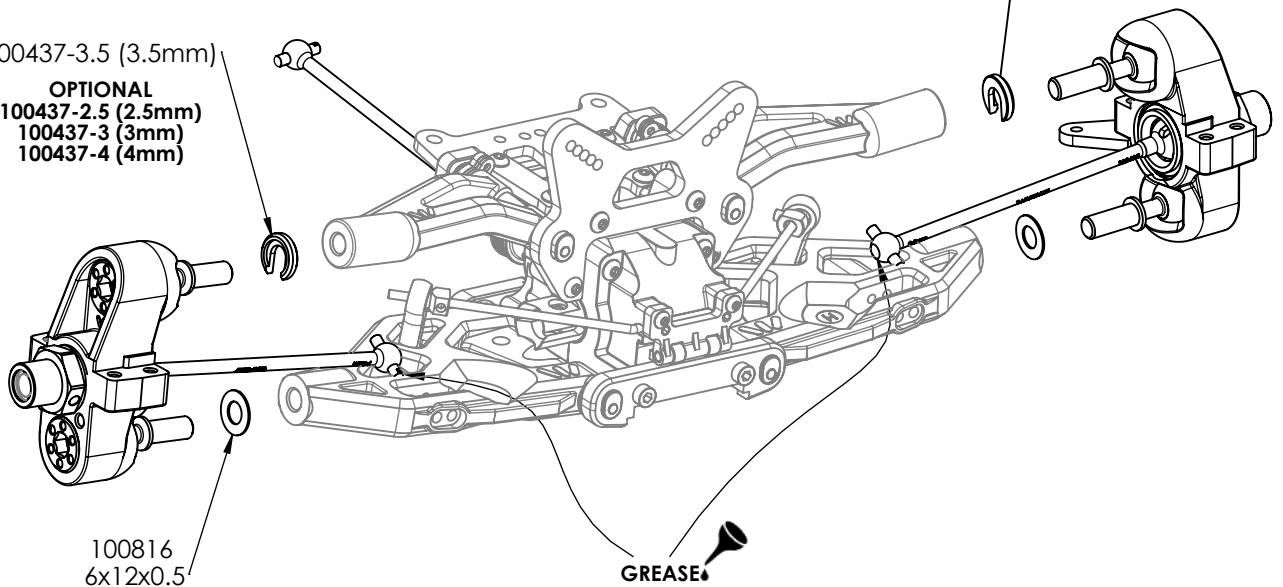

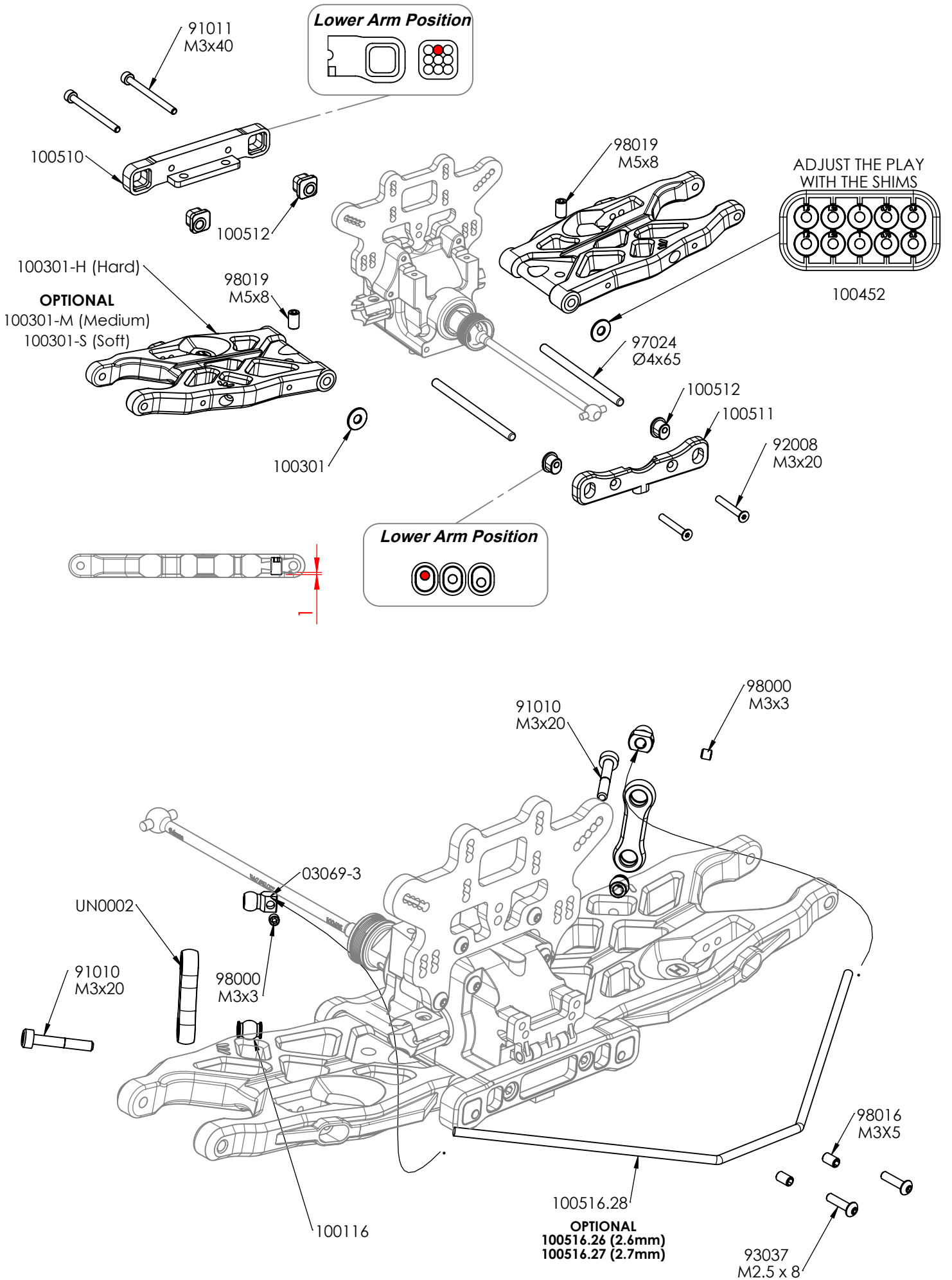

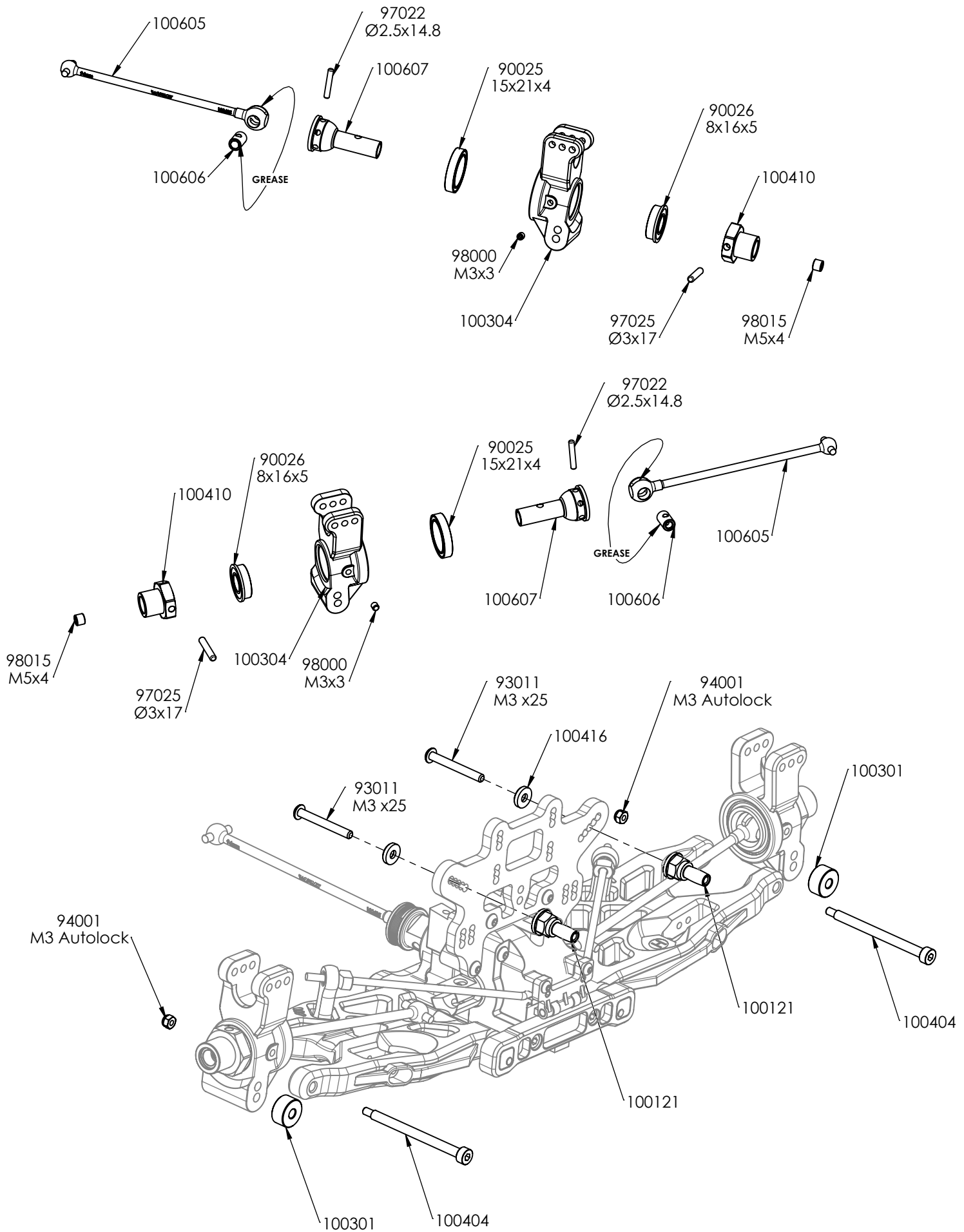

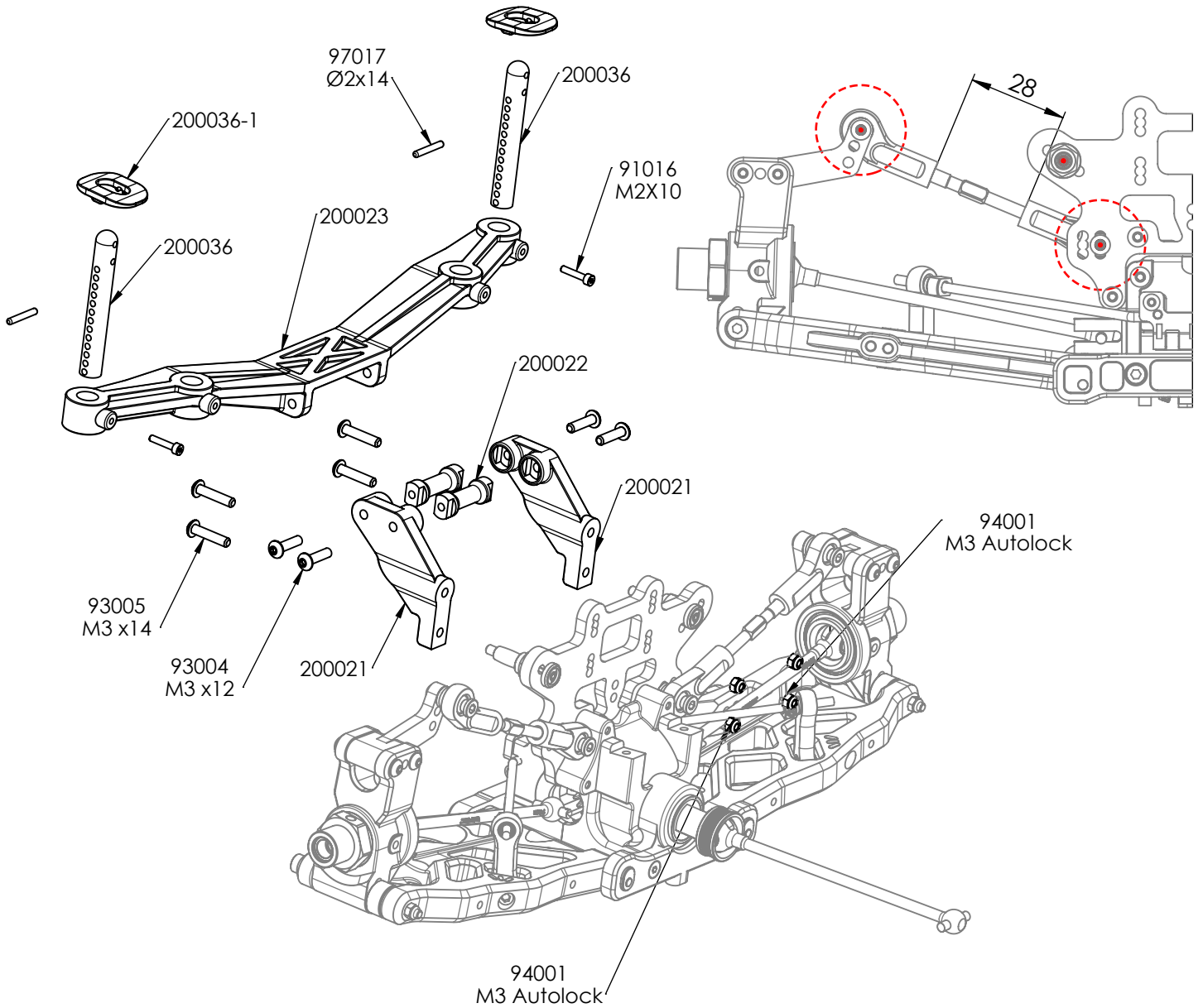
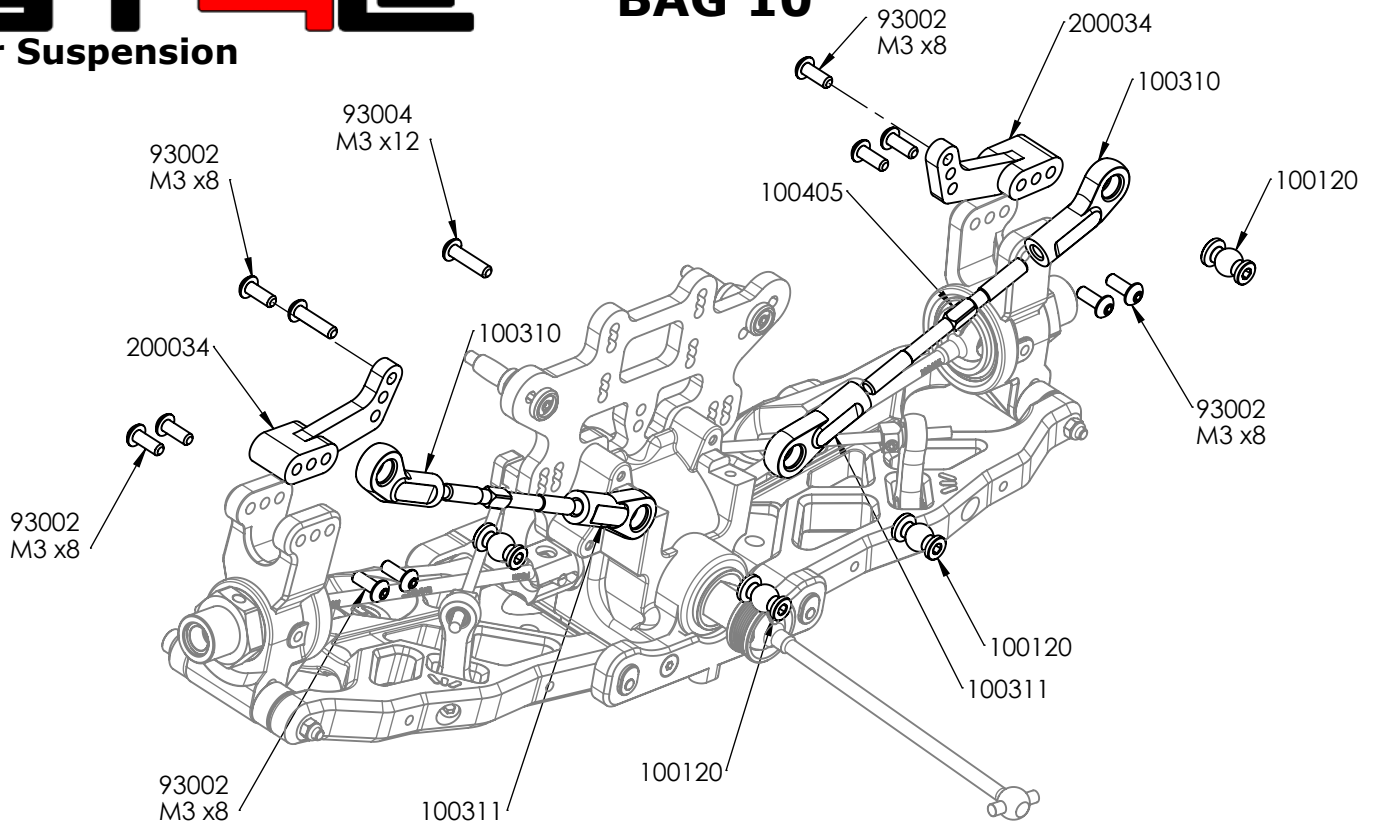

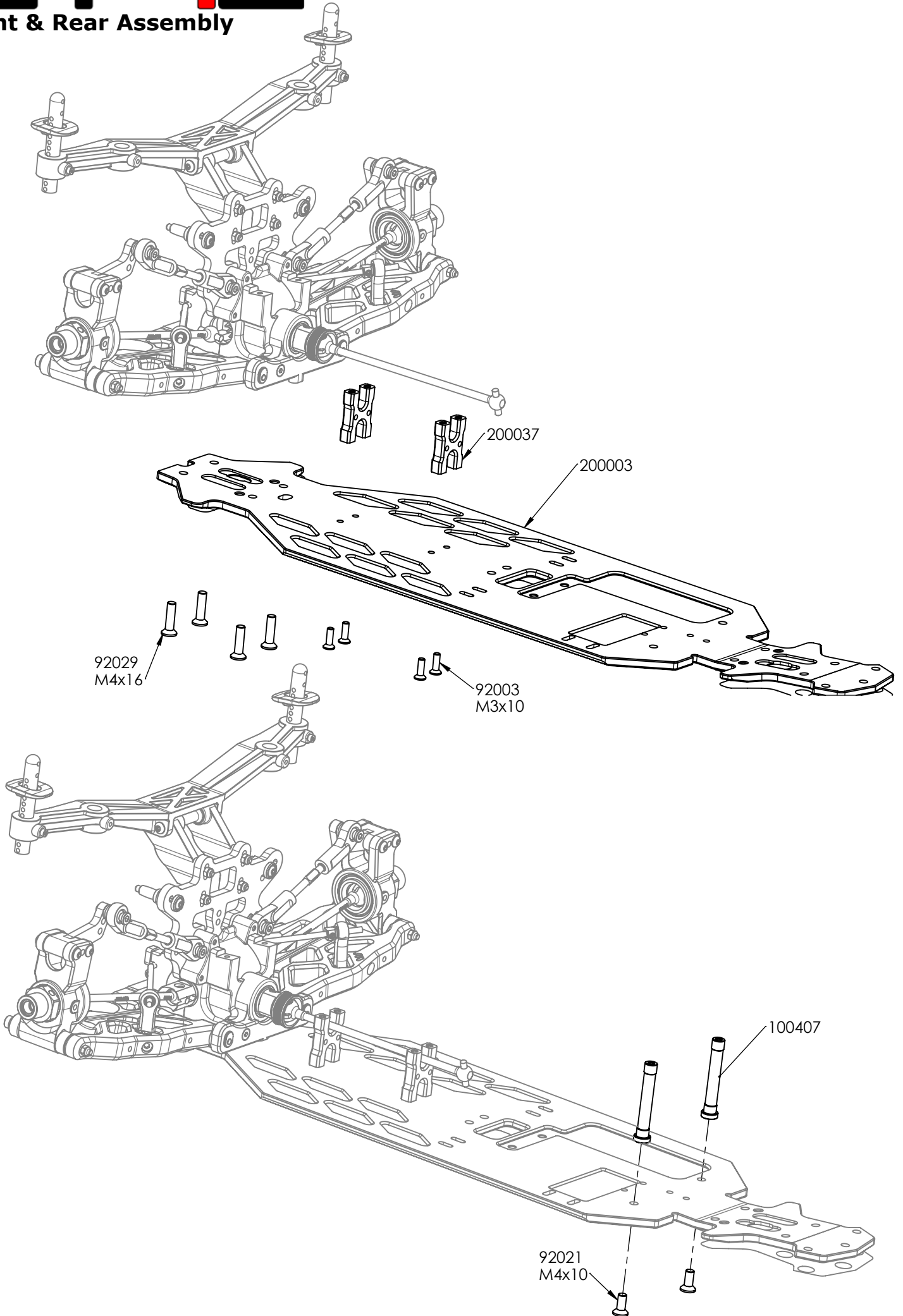

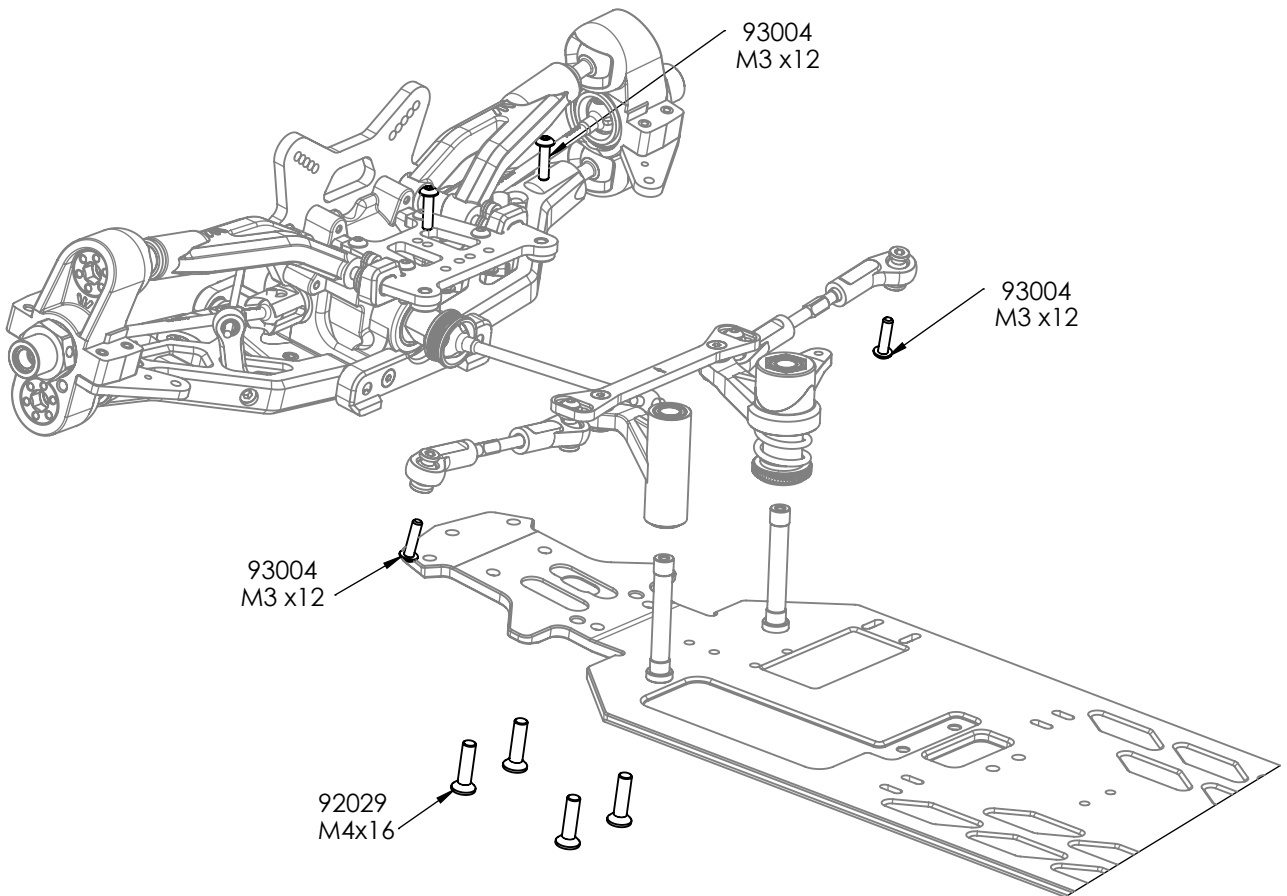
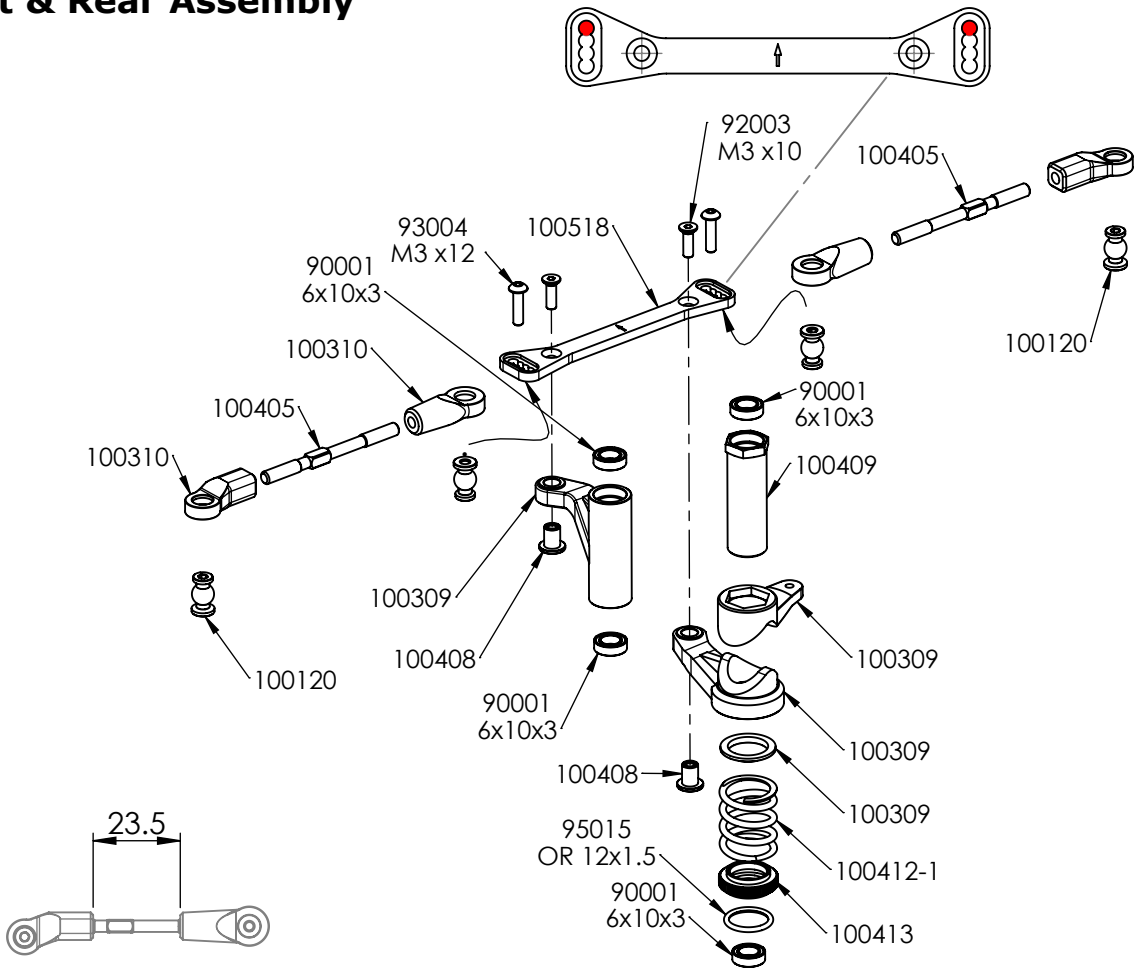

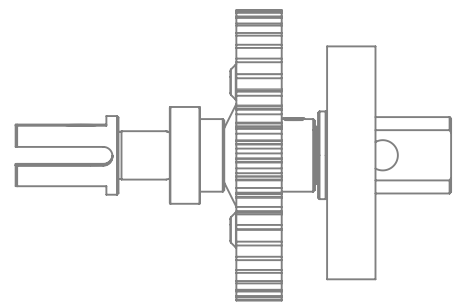
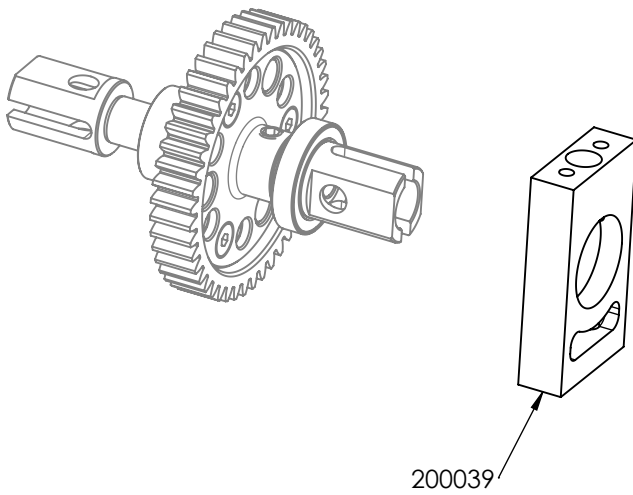
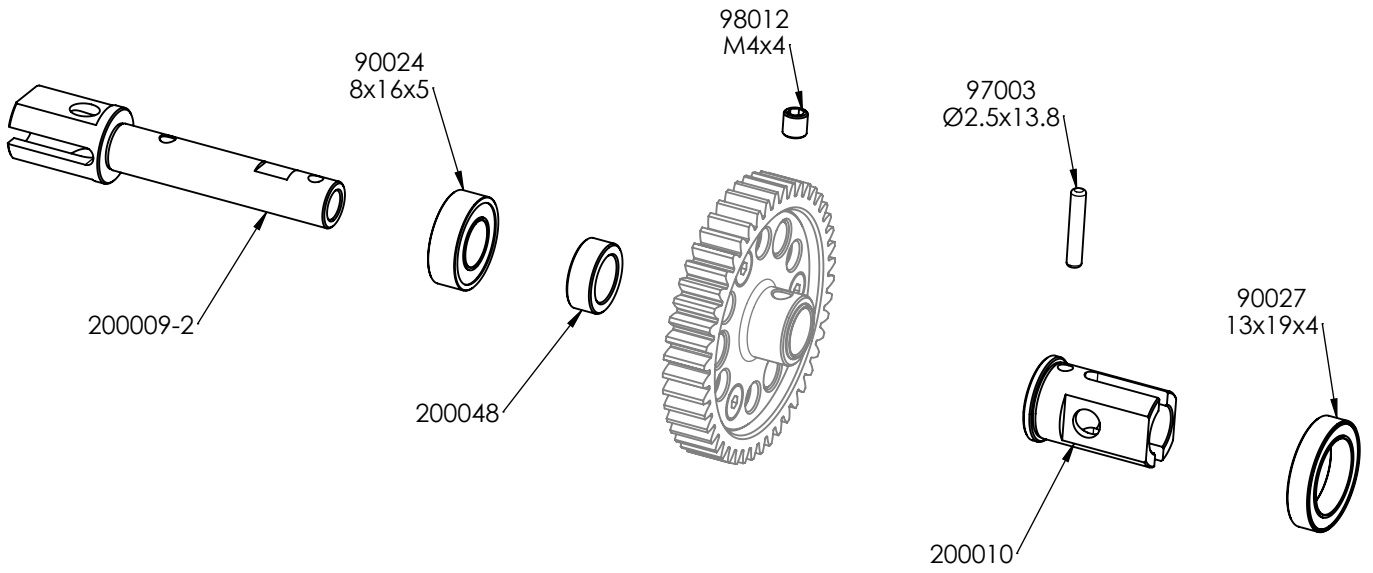
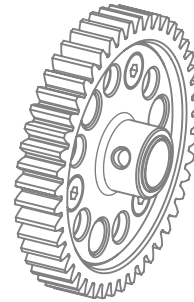
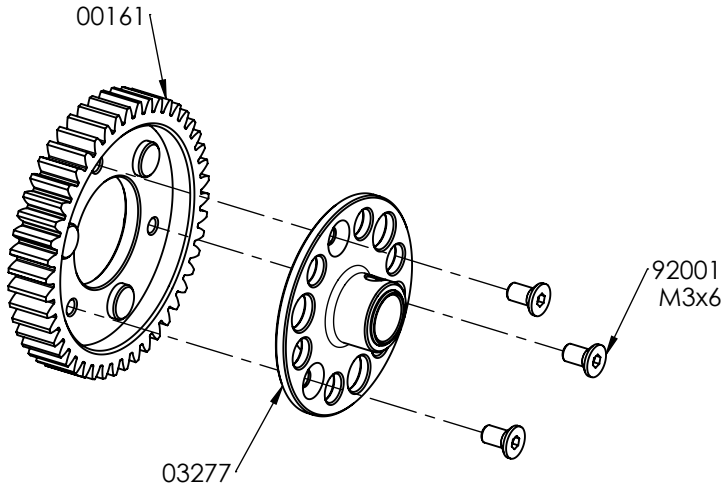

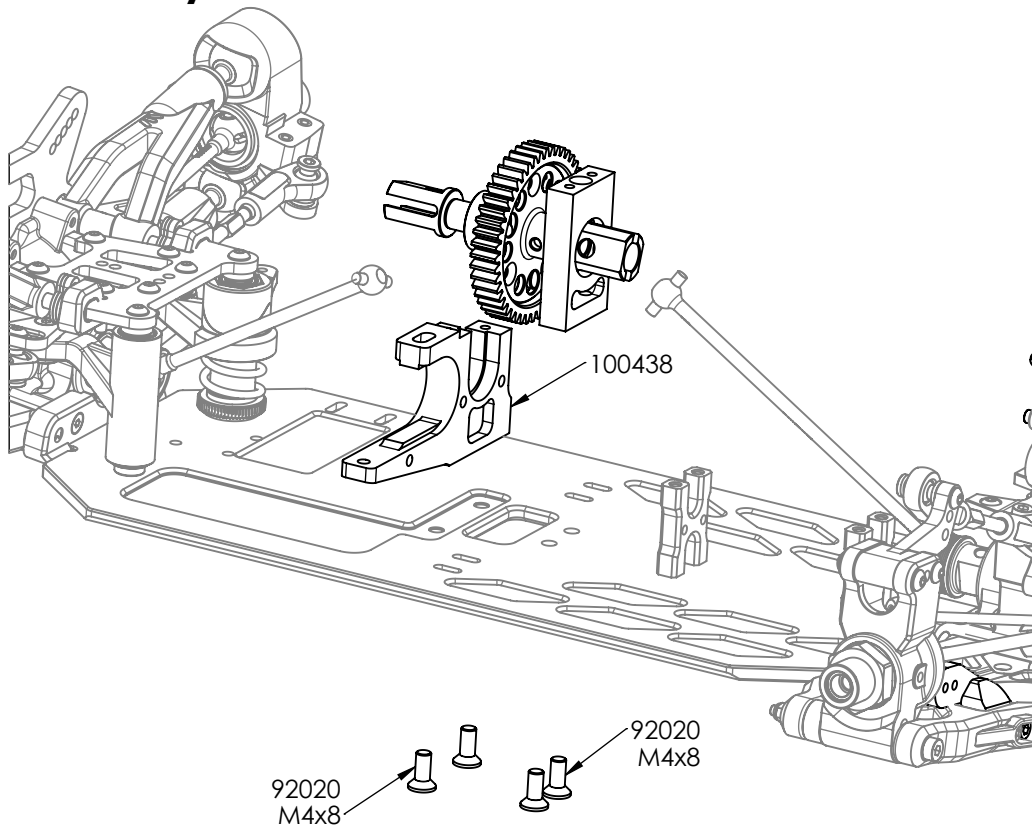

Electric motor

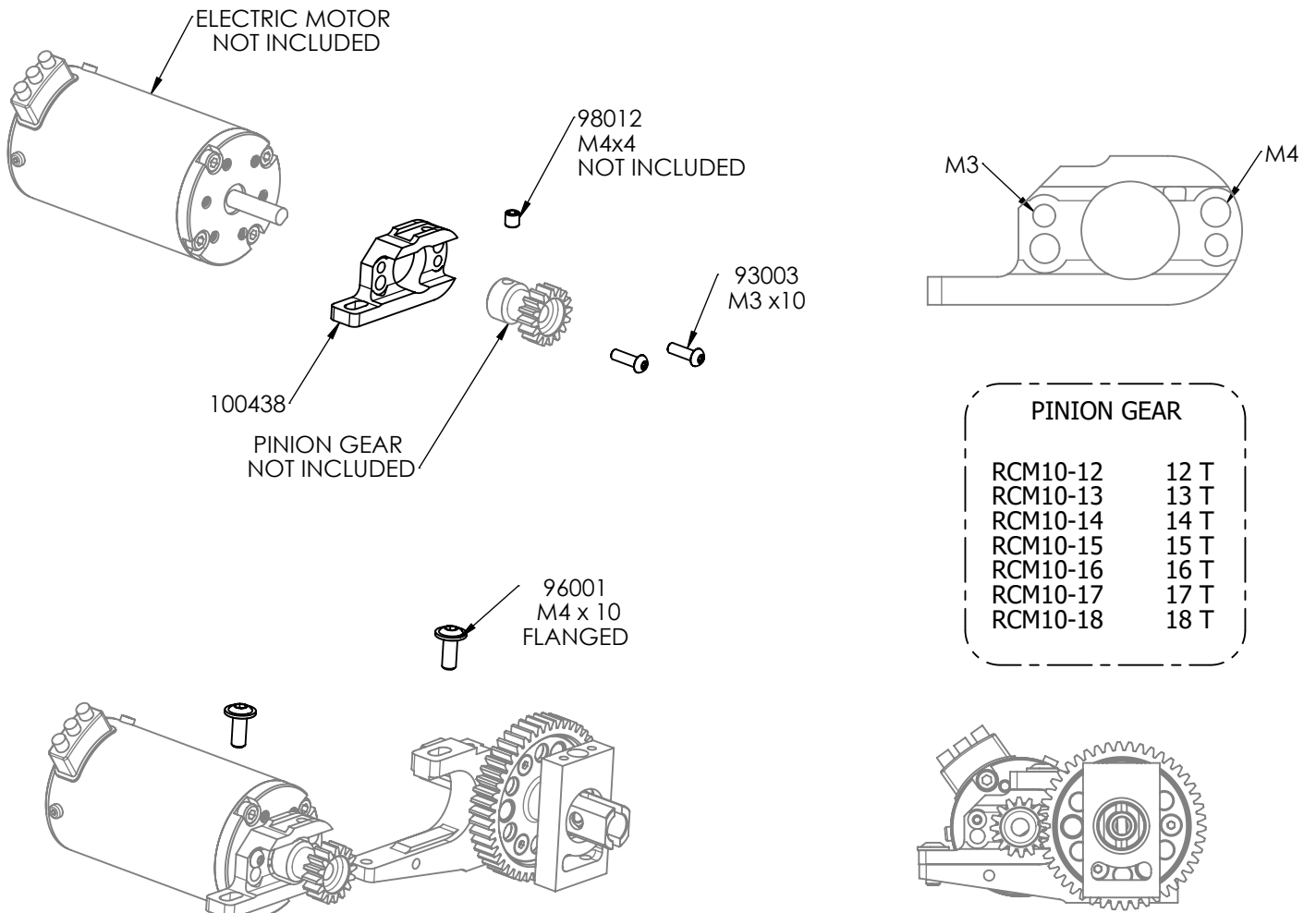

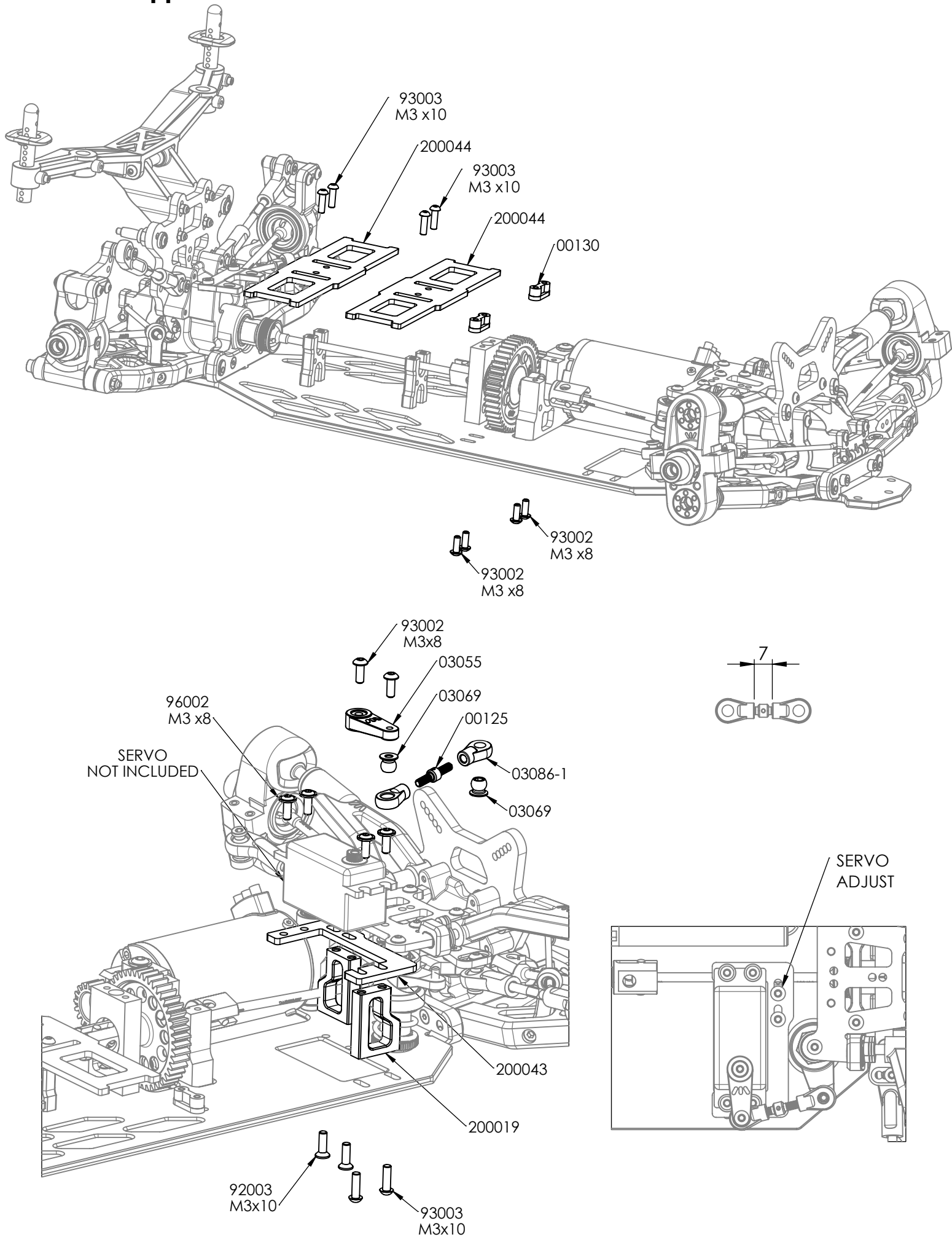

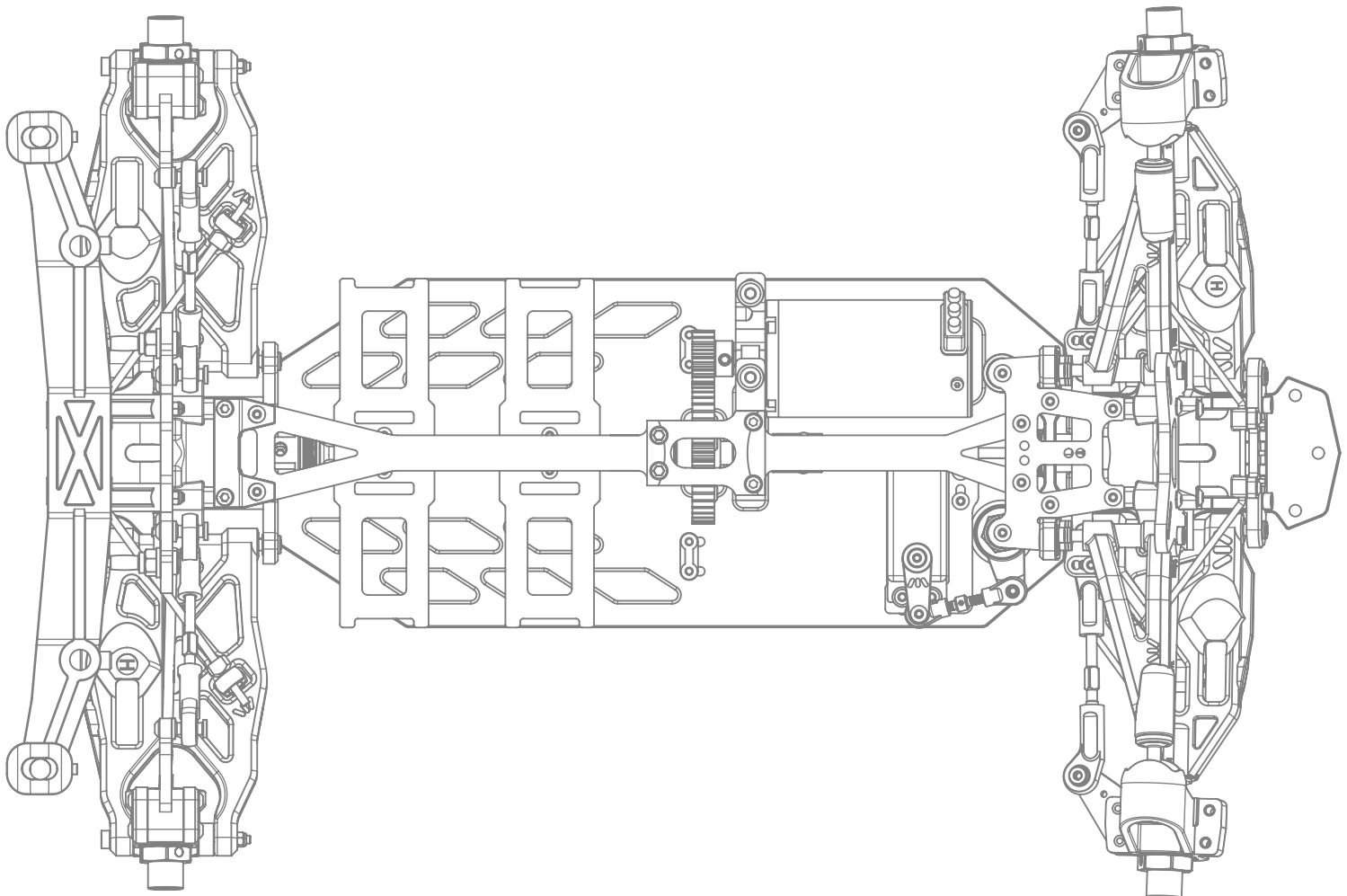
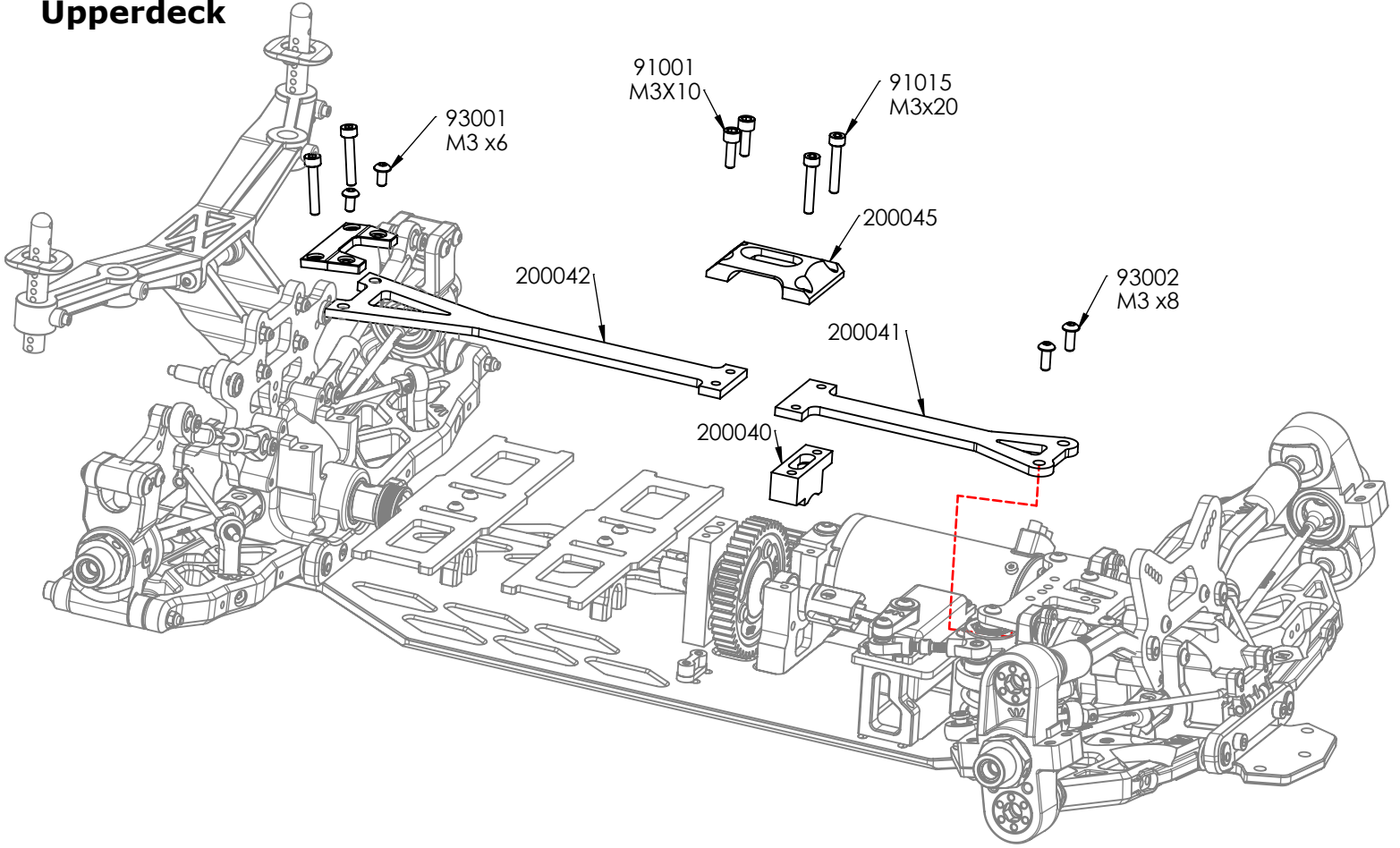

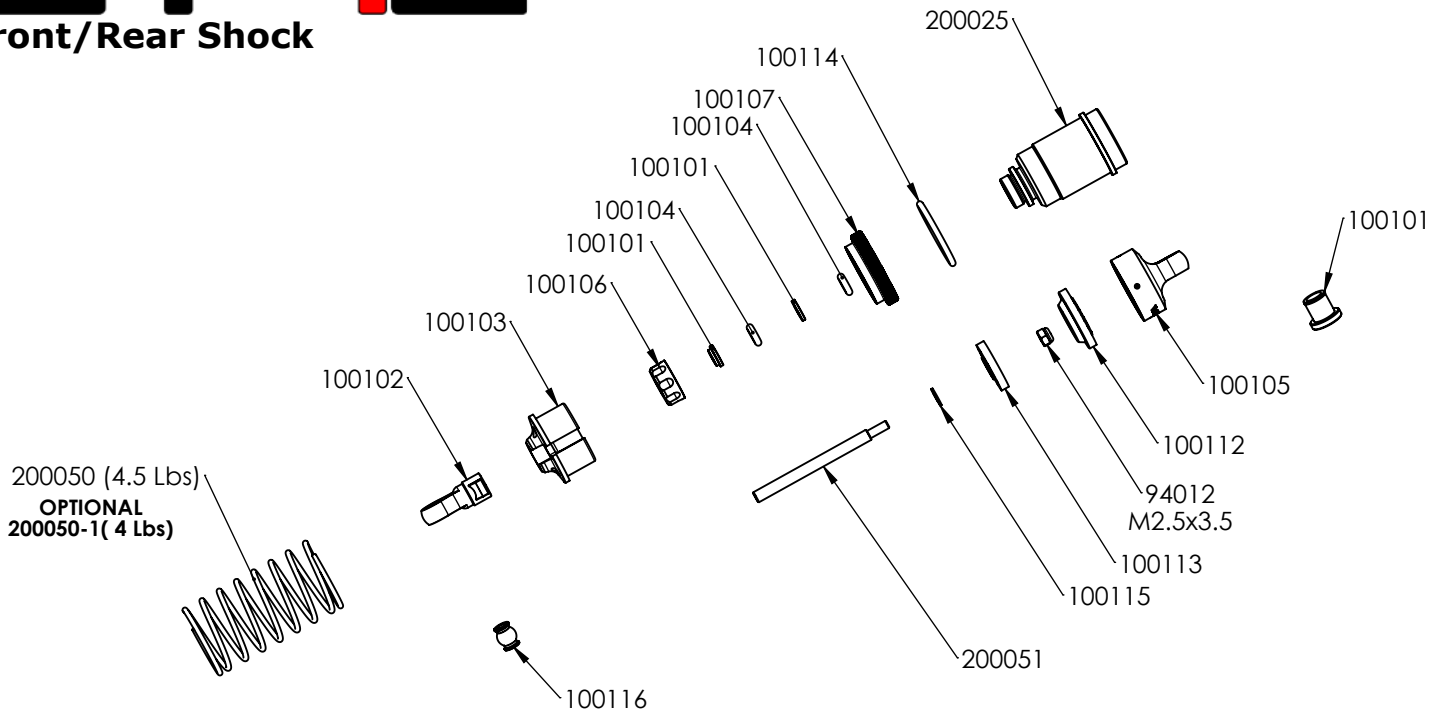

Assembly 4 set

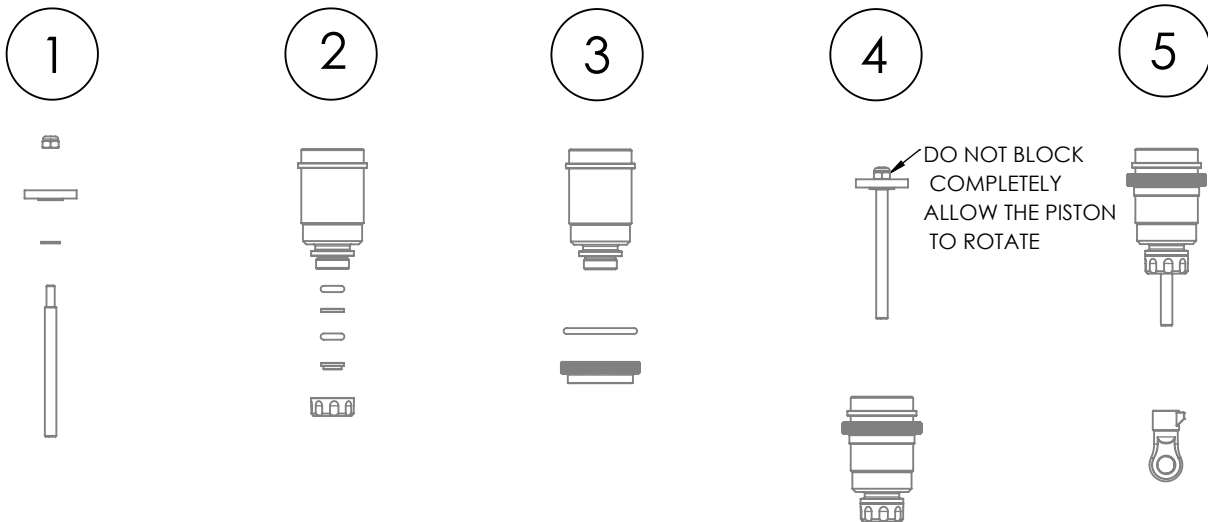

SHOCK FILLING

Fully extend the piston rod so the piston is at the bottom of the shock body.

Hold the shock upright and fill the shock body with shock oil as in the picture.

Let the oil settle and allow air bubbles to rise to the top. Slowly move the piston up and down until no more air bubbles appear. Add shock oil as necessary.

Pull the piston rod most of the way out of the shock bod. Let the shock rest for 5 minutes to allow the air bubbles to scape.



P- ONE SHOCKS OIL	
CODE	CST
SO-400	400
SO-500	500
SO-600	600
SO-700	700
SO-800	800 (IN KIT)

Set distance

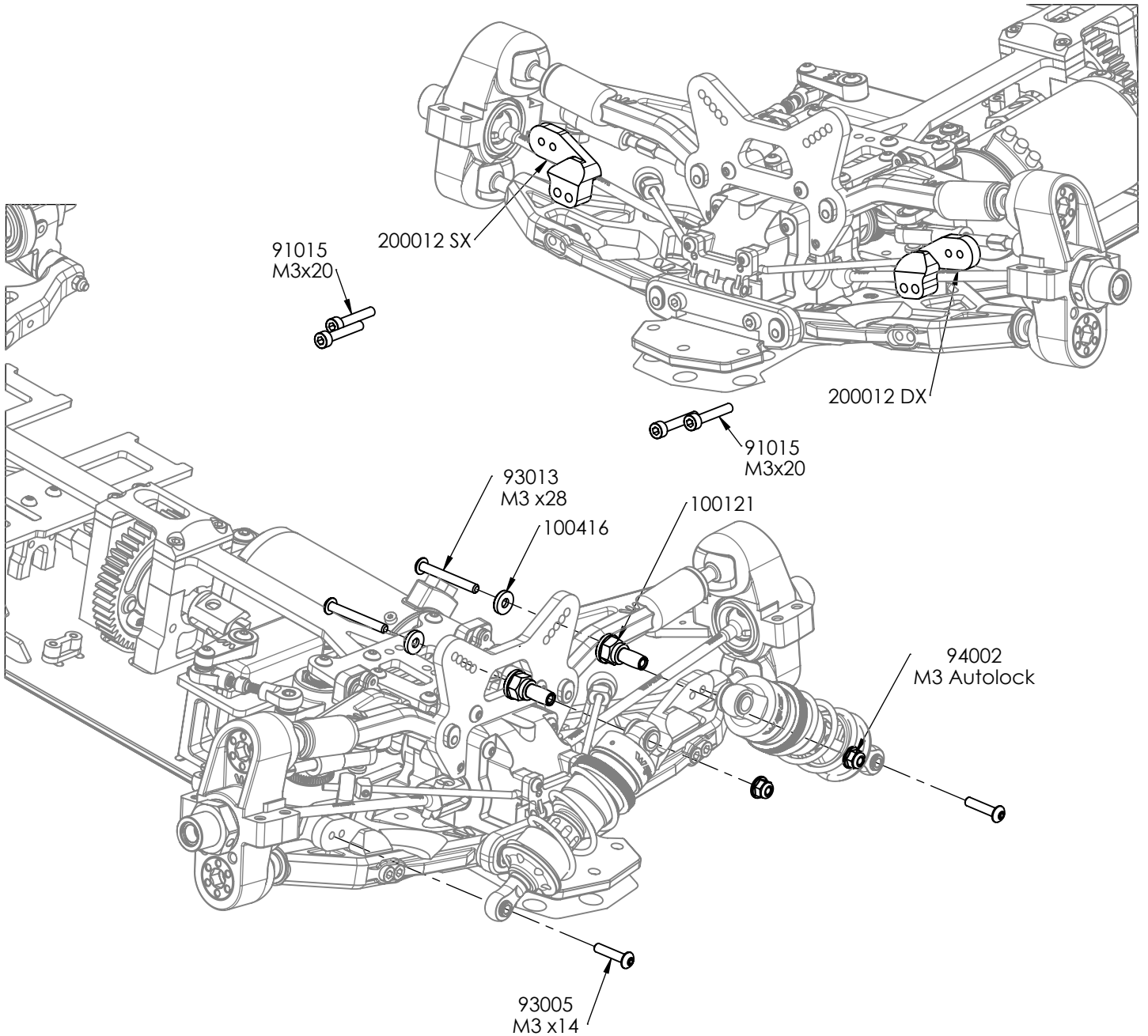
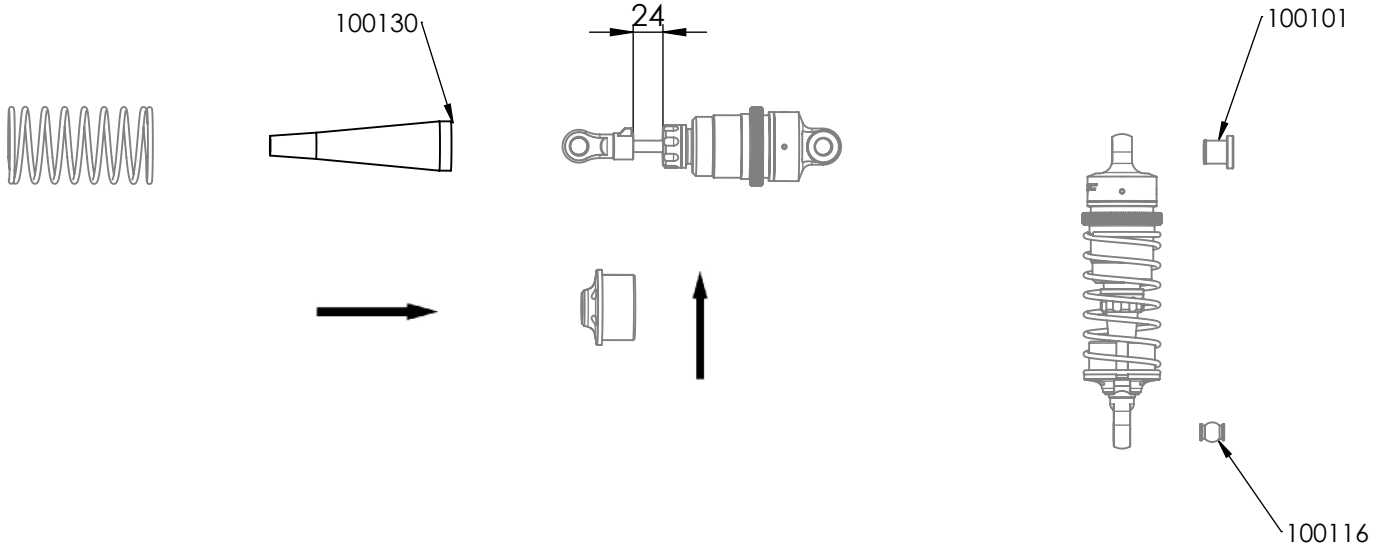

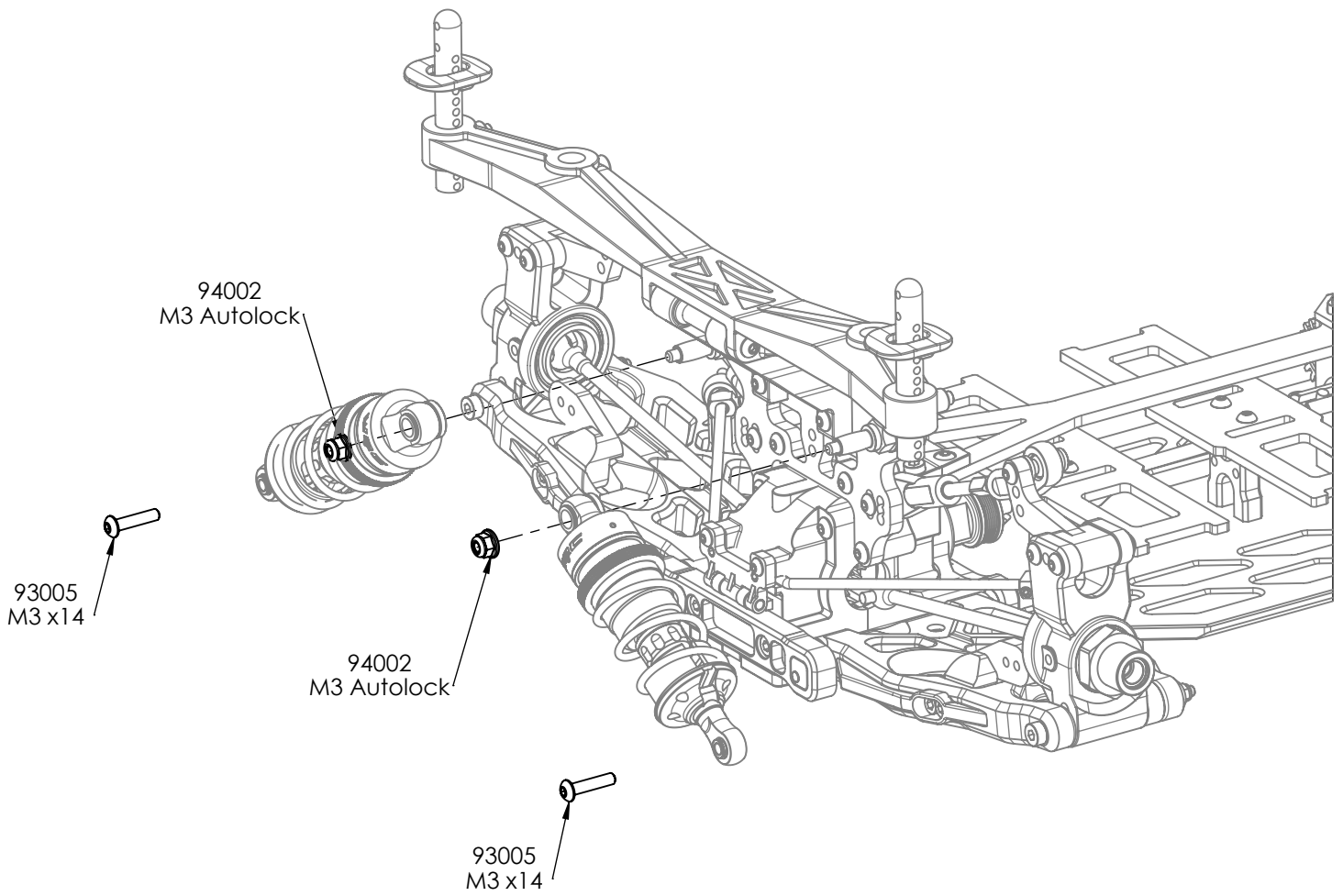
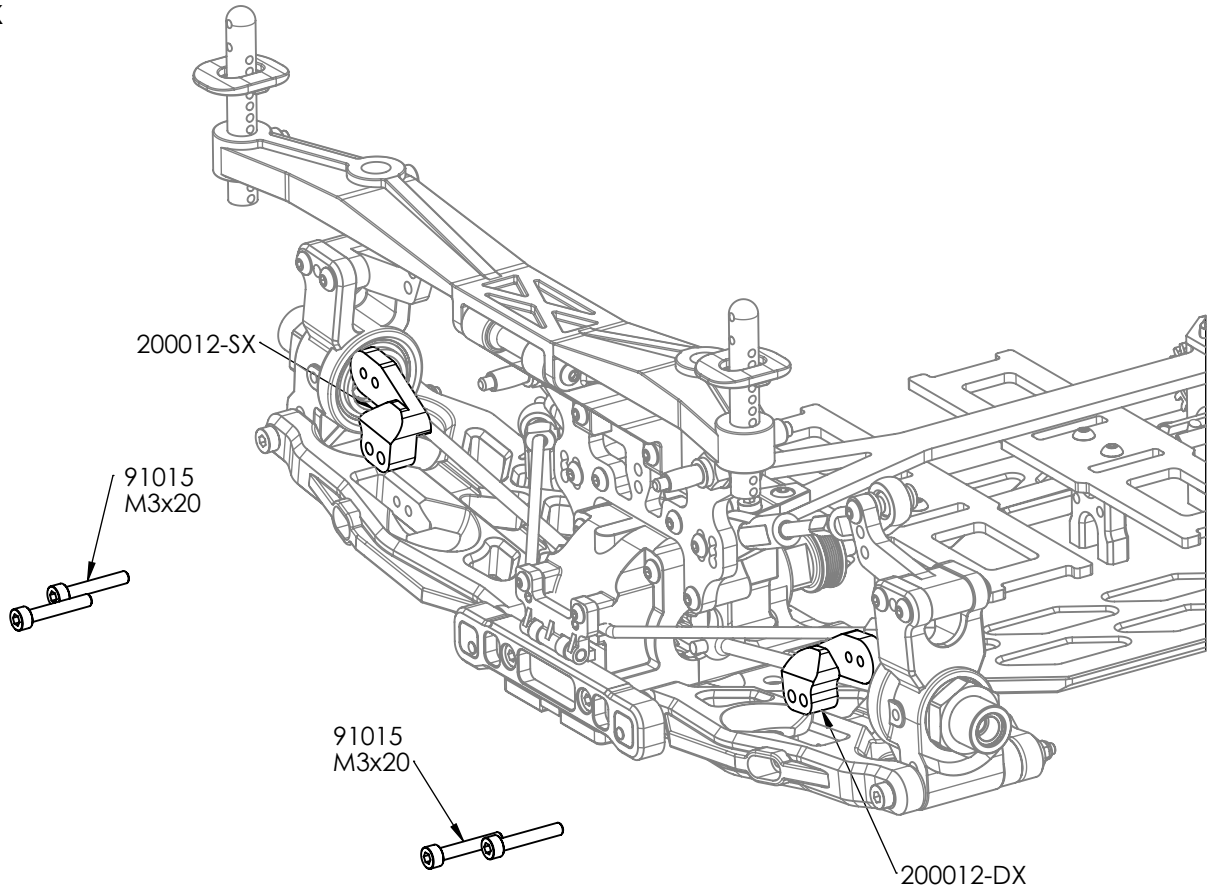

CUT TO SIZE

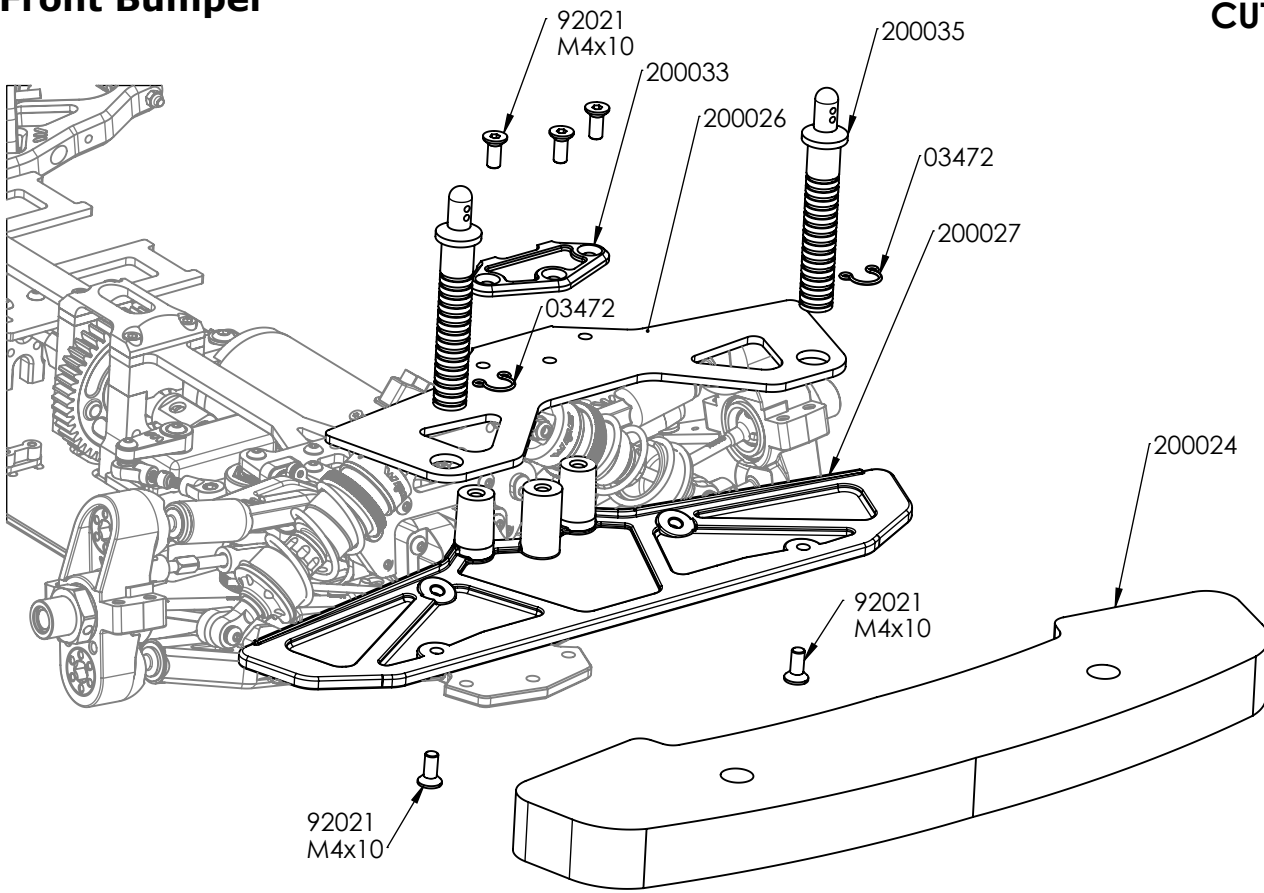
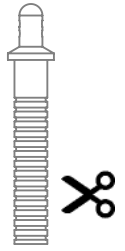

Batteries

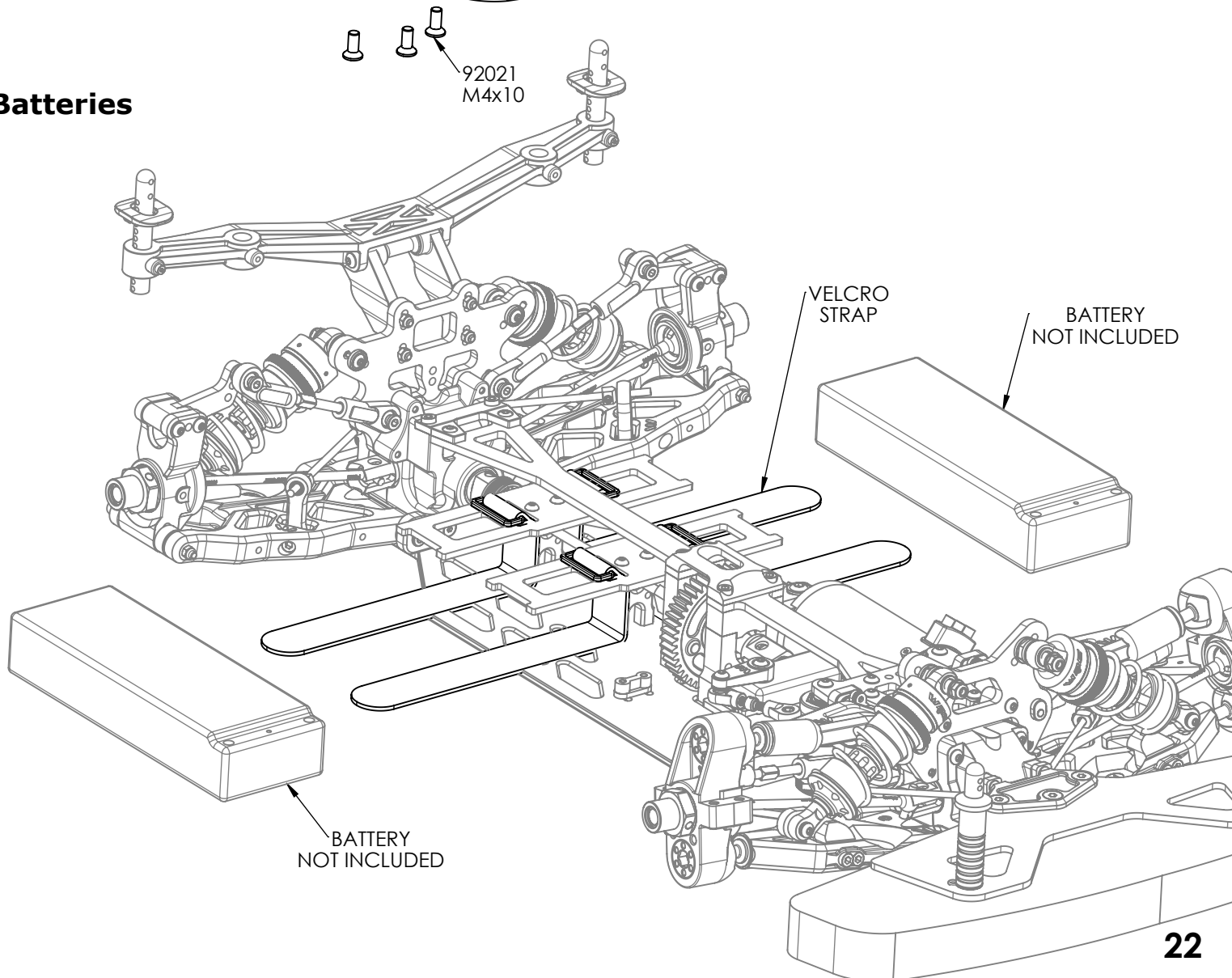

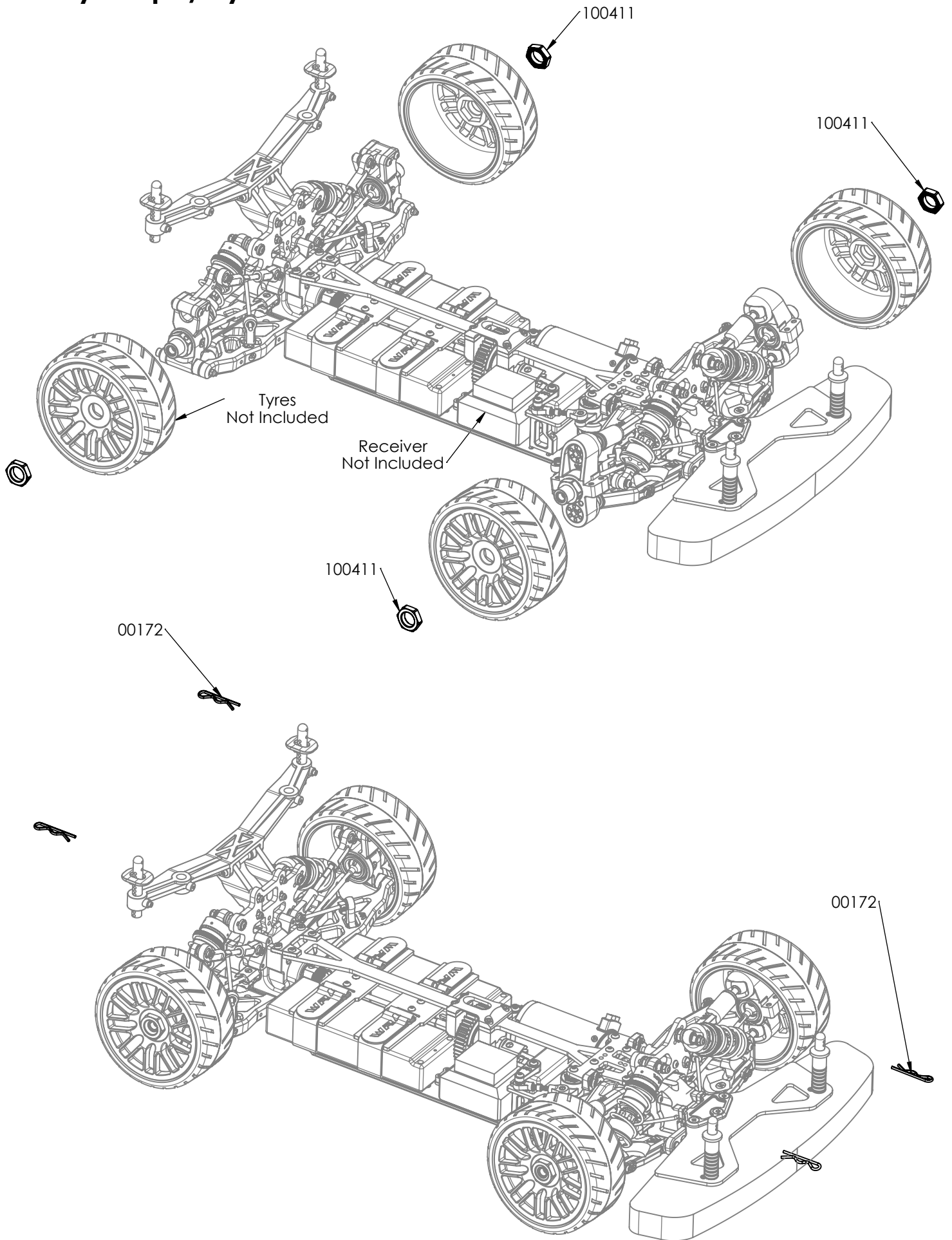

Driver: _____
Date: _____

Track: _____
Event: _____

Front Suspension:

Ride Height: _____
Camber: _____
Toe: _____
Anti-Roll Bar
Size: _____
Gap: _____
Ackerman
Drive Shaft: _____
Chassie Brace: _____
Hex: _____

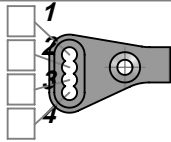
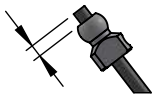

Caster Shim: _____

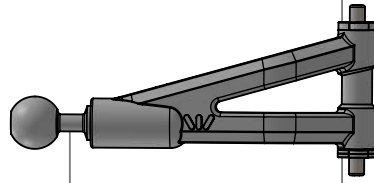

Upper Ball Type: _____
Caster Shim: _____
Upper Ball Shim: _____

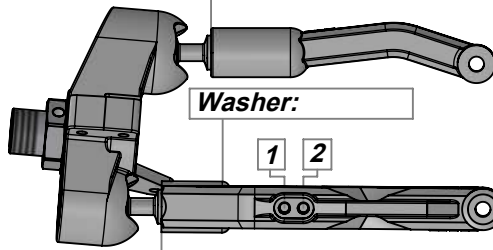

Lower Ball Shim: _____

Washer: _____

Wheelbase Shim: _____

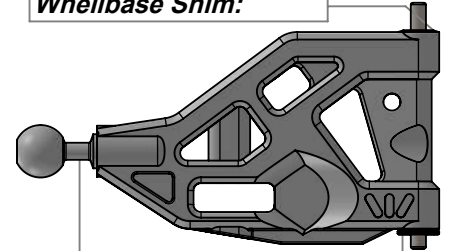

Lower Ball Type: _____
Wheelbase Shim: _____

Lower Arm Position



Upper Arm Position

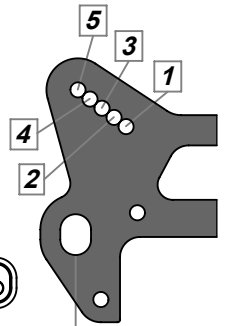

Rear Suspension:

Ride Height: _____
Camber: _____
Toe: _____
Anti-Roll Bar
Size: _____
Gap: _____
Drive Shaft: _____
Chassie Brace: _____
Hex: _____

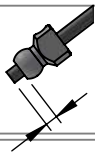

Hub Shim: _____

Hub Shim: _____

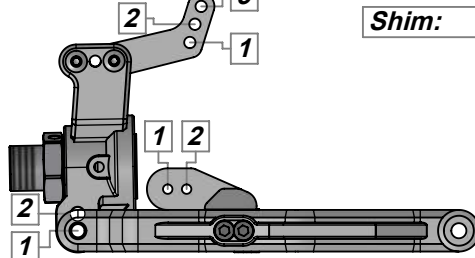
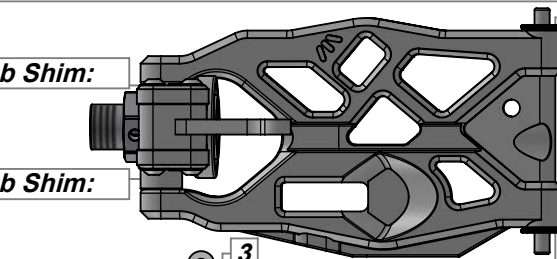

Shim: _____

Shim: _____

Lower Arm Position

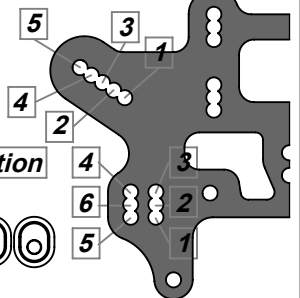
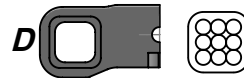
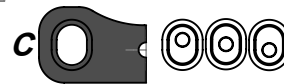

Shocks:

	Front	Rear
Piston:		
Membrane:		
Oil:		
Spring:		
Rebound:		
Free Length:		

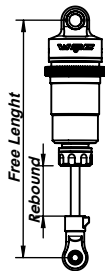

Electronics :

Radio: _____
Servo: _____
Epa: Throttle: % Brake: %
Expo: Throttle: % Brake: %
Esc: _____
Motor: _____
Battery: _____

Pinion and spur gear:

Pinion: _____
Spure gear: _____
Tracks:
Size : _____ Type: _____
Traction: _____
Surface: _____

Differentials:

	Front	Rear
Case Mat.:		
Oil:		
Crown Gear:		

Body, Wing:

Body: _____
Wing: _____
Manifold: _____
Wing Height: _____
Gap to tower: _____

Tires:

	Front	Rear
Brand:		
Pattern:		
Insert:		
Whells:		
Compound:		

Note:

Tot. Car Weight: _____



W.R.C. world racing car s.r.l.

www.wrc-racing.com